



DESIGN REVIEW BOARD Staff Report

Planning and Environmental Services
130 Cremona Drive, Suite B, Goleta, CA 93117
Phone: (805)961-7500 Fax: (805)961-7551
www.cityofgoleta.org

AGENDA ITEM H-2

DATE: July 13, 2010
TO: Goleta Design Review Board
FROM: Brian Hiefield, Assistant Planner
SUBJECT: 10-071; World Oil Unocal 76 Fuel Station; 5648 Hollister Avenue;
APN 071-082-006

APPLICANT: Promotion Plus Sign Co Inc
Yessica Sanchez
9420 Reseda Blvd # 250
Northridge, CA 91324

PROJECT DESCRIPTION:

This is a request for *Conceptual/Preliminary/Final* review. The property includes an existing fuel station and convenience store on a 13,503-square foot lot in the C-2 zone district. The applicant proposes to re-face the existing pole sign with a new vacuum formed plex face measuring 12-feet high by 8.2-feet wide for an aggregate of approximately 98 square feet. The total height of the pole sign would remain 21.75-feet tall. The sign will have the circular Unocal 76 logo measuring 3' high on the top portion of the sign, and the prices on the lower portion with numbers measuring 1.25' high. The applicant also proposes to install two internally illuminated circular Unocal 76 logos on the existing canopy measuring 2.75-feet high, one on the north elevation, and one on the south elevation, each totaling approximately 8 square feet. The project was filed by agent Yessica Sanchez of Promotion Plus Sign Co Inc. on behalf of Joe Partida of World Oil, property owner. Related cases: 10-068-SCC; 10-069-SCC; 10-070-SCC.

BACKGROUND:

The project was submitted on May 10, 2010. This is the first time the project has been before the DRB. There are no known violations on the property.

ANALYSIS:

Zoning Consistency:

	Required	Proposed	Consistent Y/N
Freestanding Signs	One on each parcel provided there is at least 125-feet of street frontage. No part of sign or supporting structure shall project over Public Right-of-Way (ROW). Base of supporting structure shall be at least 5-feet from ROW. Sign area not to exceed 100 square feet. Sign height not to exceed 30-feet.	Re-face of previously permitted pole sign. Not projecting over ROW. Location of base of supporting structure remains as approved by Santa Barbara County Variance 79-V-048. Sign area 98 square feet. Sign overall height 21-foot 9-inches.	Yes
Canopy, Wall Signs	One per street frontage (2). 1/8 th of the building façade of the first floor of the façade the wall sign is to be located: Hollister Avenue frontage: 29.7 square feet Kinman Avenue frontage: 9.8 square feet	2 Canopy Signs Hollister Avenue frontage: 7.6 square feet North facing canopy: 7.6 square feet	No (North facing canopy not a street frontage)



The proposed project is yet to be determined consistent with the above requirements of Article I, Chapter 35, Sign Regulations.

ISSUES:

- **North Facing Canopy Sign:** Proposed sign on north facing canopy is not a street frontage. Consider relocation options to come into compliance with the sign regulations in Article I.

ATTACHMENTS:

- Reduced 11" x 17" copies of site plans and elevations.

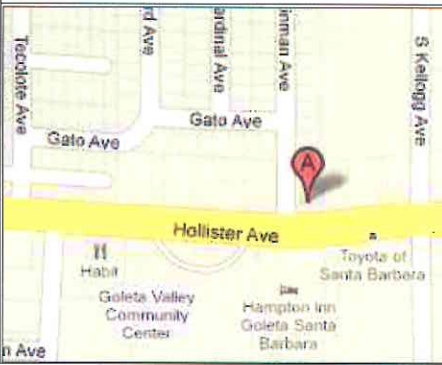
PROJECT PHOTOS	PROPOSED IMAGES	PROJECT DATA	INDEX OF DRAWINGS																											
		<p>PROJECT DESCRIPTION: EXXON CONVERSION TO OASIS</p> <p>OWNER WORLD OIL PO BOX 1966 SOUTHGATE, CA 90280 (562) 928-0100</p> <p>APPLICANT PROMOTION PLUS, INC. 9420 RESEDA BLVD # 250 NORTHRIDGE, CA 91324 TEL. (818)993-5406 FAX. (818)993-3174</p>	<table border="1"> <thead> <tr> <th>NO.</th> <th>SHT.</th> <th>DESCRIPTION</th> </tr> </thead> <tbody> <tr> <td colspan="3">TITLE SHEETS</td> </tr> <tr> <td>1</td> <td></td> <td>TITLE PAGE</td> </tr> <tr> <td>2</td> <td></td> <td>POLE SIGN RENDERING</td> </tr> <tr> <td>3</td> <td></td> <td>SIGN SPECS</td> </tr> <tr> <td>4</td> <td></td> <td>CANOPY RENDERING</td> </tr> <tr> <td>5</td> <td></td> <td>CANOPY SPECS</td> </tr> <tr> <td>6</td> <td></td> <td>CANOPY SIGN SPECS</td> </tr> <tr> <td>7</td> <td></td> <td>PLOT PLAN</td> </tr> </tbody> </table> <p style="text-align: center;">VICINITY MAP</p>  <div style="text-align: center; font-size: 2em; color: blue; font-weight: bold;">RECEIVED</div> <div style="text-align: center; color: blue;"> <p>JUN 30 2010</p> <p>City of Goleta Planning & Environmental Svcs.</p> </div>	NO.	SHT.	DESCRIPTION	TITLE SHEETS			1		TITLE PAGE	2		POLE SIGN RENDERING	3		SIGN SPECS	4		CANOPY RENDERING	5		CANOPY SPECS	6		CANOPY SIGN SPECS	7		PLOT PLAN
NO.	SHT.	DESCRIPTION																												
TITLE SHEETS																														
1		TITLE PAGE																												
2		POLE SIGN RENDERING																												
3		SIGN SPECS																												
4		CANOPY RENDERING																												
5		CANOPY SPECS																												
6		CANOPY SIGN SPECS																												
7		PLOT PLAN																												
NEW SIGNAGE PROGRAM		<p>ADDRESS & SITE NUMBER</p> <p>5648 HOLLISTER AVE. GOLETA, CA 93117</p>																												

REVISIONS	BY
△	
△	
△	
△	
△	

PLEASE AUTHORIZE HERE X
 WITHOUT AUTHORIZATION PROMOTION PLUS IS UNABLE TO PROCESS YOUR ORDER.
PROMOTION PLUS
"Dedicated to Increasing Your Profit"
 PH: 818-993-5406 / FX: 818-993-3174
 St. Lic. 853228
 E-MAIL PERMITS@PROMOTIONPLUSINC.COM

DRAWN YESSICA SANCHEZ
CHECKED
DATE 06-28-2010
SHEET TITLE TITLE PAGE
JOB NO.
SHEET 1

BEFORE



AFTER

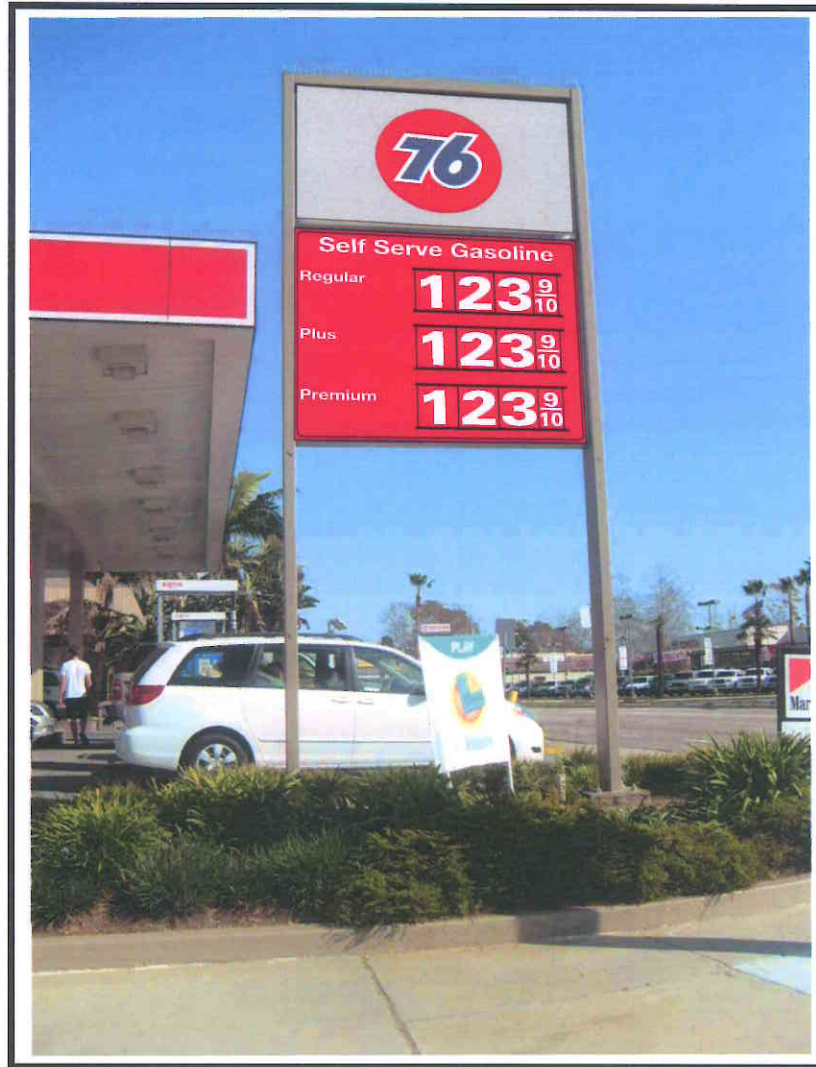

REVISIONS	BY
1	
2	
3	
4	
5	

PLEASE AUTHORIZE HERE WITHOUT AUTHORIZATION PROMOTION PLUS IS UNABLE TO PROCESS YOUR ORDER.

Signs & Service

LOCATION:
REVISION #:
Computer info:

PROMOTION PLUS
"Indicated in increasing tier pricing."
PH: 818-993-5406 / FX: 818-993-3174
E-MAIL PERMITS@PROMOTIONPLUSING.COM
St. Lic. 863228

DRAWN YESSICA SANCHEZ
CHECKED
DATE 06-28-2010
SHEET TITLE POLE SIGN RENDERING JOB NO.
SHEET 2

98" x 144"
 Vacuum Formed Plex
 Face Replacements

98 sqft

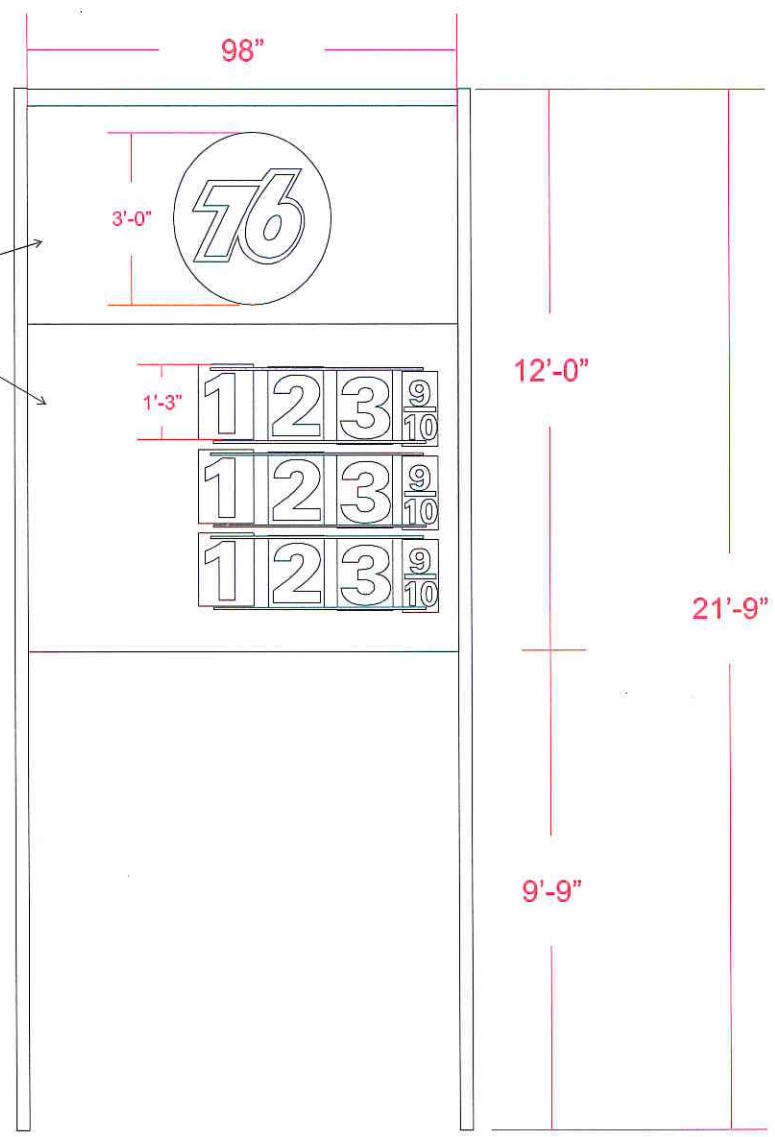

REVISIONS	BY
1	
2	
3	
4	
5	

PLEASE AUTHORIZE HERE **X**
 WITHOUT AUTHORIZATION PROMOTION PLUS IS UNABLE TO PROCESS YOUR ORDER.
Signs & Service
PROMOTION PLUS
Distributor for the following states: Florida, Michigan
 PH: 818-993-3406 / FX: 818-993-3174
 E-MAIL: PERMITS@PROMOTIONPLUSINC.COM St. Lic. 853228

DRAWN YESSICA SANCHEZ
CHECKED
DATE 06-28-2010
SHEET TITLE SIGN SPECS
JOB NO.
SHEET 3

BEFORE



AFTER



REVISIONS	BY
1	
2	
3	
4	
5	

PLEASE AUTHORIZE HERE X
 WITHOUT AUTHORIZATION PROMOTION PLUS IS UNABLE TO PROCESS YOUR ORDER.
PROMOTION PLUS
 A Division of
PH: 818-993-5406 / FX: 818-993-3174
 St. Lic. 653228
 E-MAIL: PERMITS@PROMOTIONPLUSINC.COM

DRAWN YESSICA SANCHEZ
CHECKED
DATE 06-28-2010
SHEET TITLE CANOPY RENDERING
JOB NO.
SHEET 4

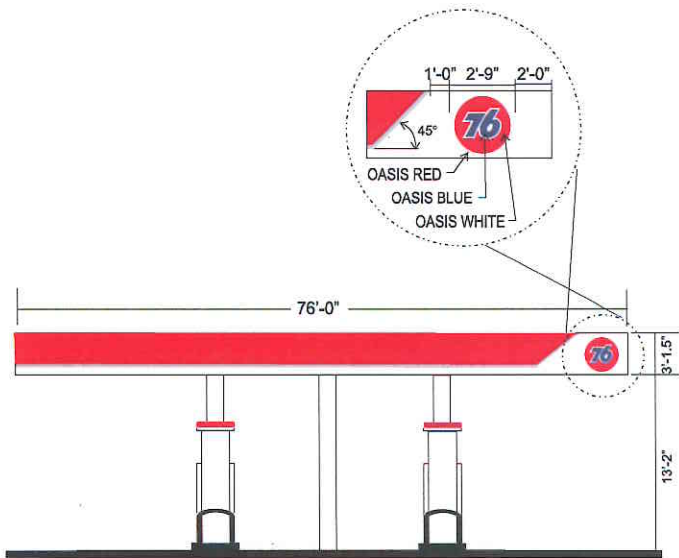

PROPOSED NORTH ELEVATION

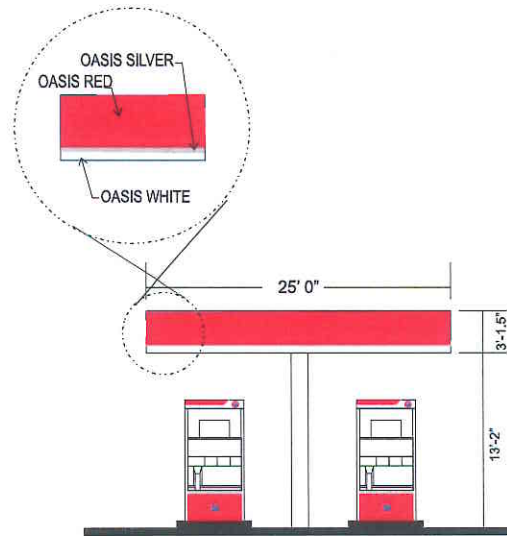

PROPOSED WEST ELEVATION

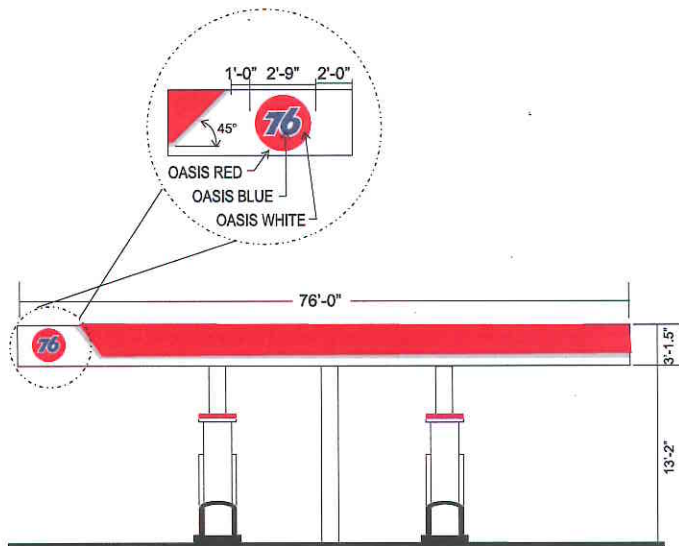

PROPOSED SOUTH ELEVATION

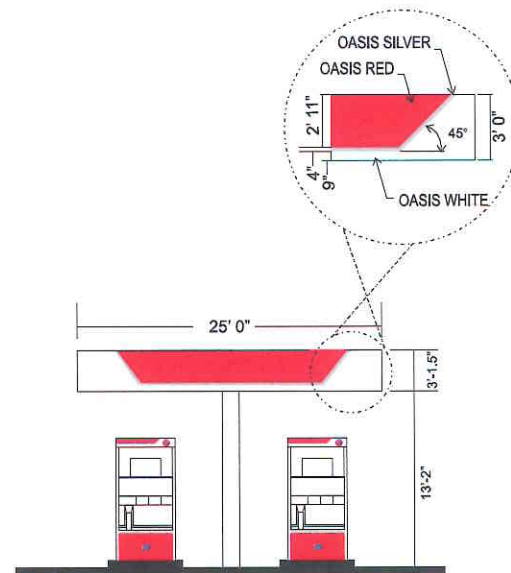

PROPOSED EAST ELEVATION

REVISIONS	BY
1	
2	
3	
4	
5	

PLEASE AUTHORIZE HERE WITHOUT AUTHORIZATION PROMOTION PLUS IS UNABLE TO PROCESS YOUR ORDER.

PROMOTION PLUS
"Dedicated to increasing your profit"
 PH: 818-993-5406 / FX: 818-993-3174
 E-MAIL PERMITS@PROMOTIONPLUSINC.COM St. Lic. 853228

Signs & Service

LOCATION:

REVISION #:

Computer info:

DRAWN	YESSICA SANCHEZ
CHECKED	
DATE	06-28-2010
SHEET TITLE	CANOPY SPECS
JOB NO.	
SHEET	5



ILLUMINATED CAN SIGN SPECIFICATIONS

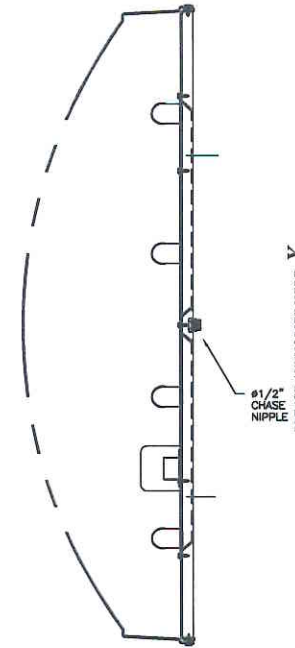
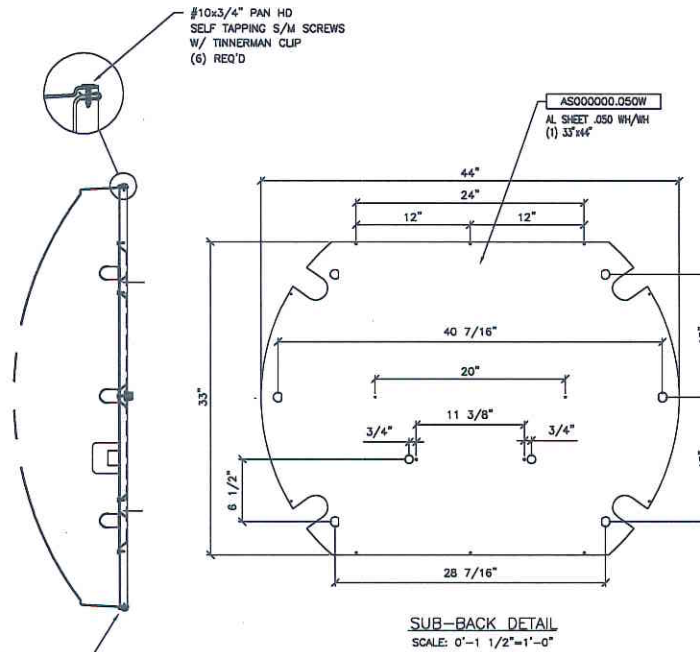
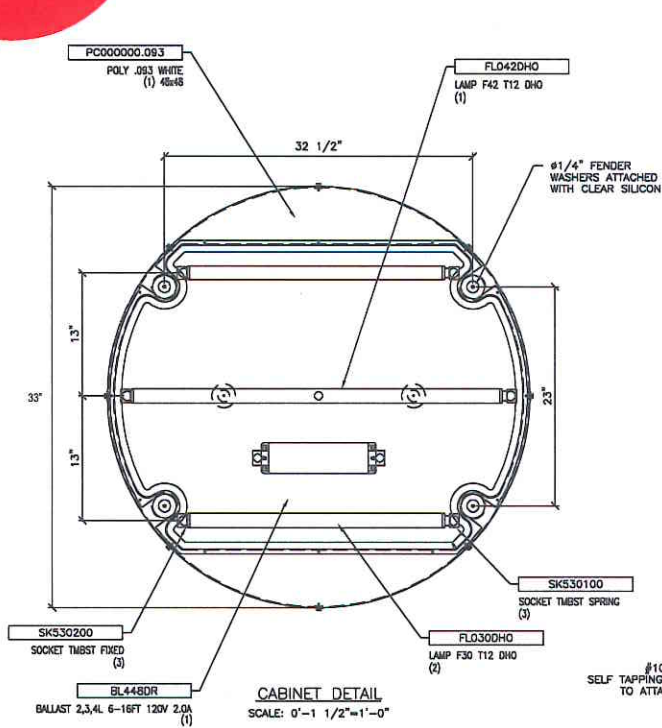

REVISIONS	BY
1	
2	
3	
4	
5	

PLEASE AUTHORIZE HERE X
WITHOUT AUTHORIZATION PROMOTION PLUS IS UNABLE TO PROCESS YOUR ORDER.

PROMOTION PLUS
"Innovation In Advertising, Now Profitable"
PH: 818-993-5406 / FX: 818-993-3174
St. Lc. 853228

Signs & Service
E-MAIL PERMITS@PROMOTIONPLUSINC.COM

LISTED MARKS:





1. LISTED MARK SIGN SECTION LABEL SHALL BE ON EACH LETTER AND TRANSFORMER ENCLOSURE.

THE FIRST BLANK SPACE IDENTIFIES THE NUMBER OF EACH SIGN SECTION. THE SECOND BLANK SPACE IDENTIFIES THE TOTAL NUMBER OF SIGN SECTIONS.

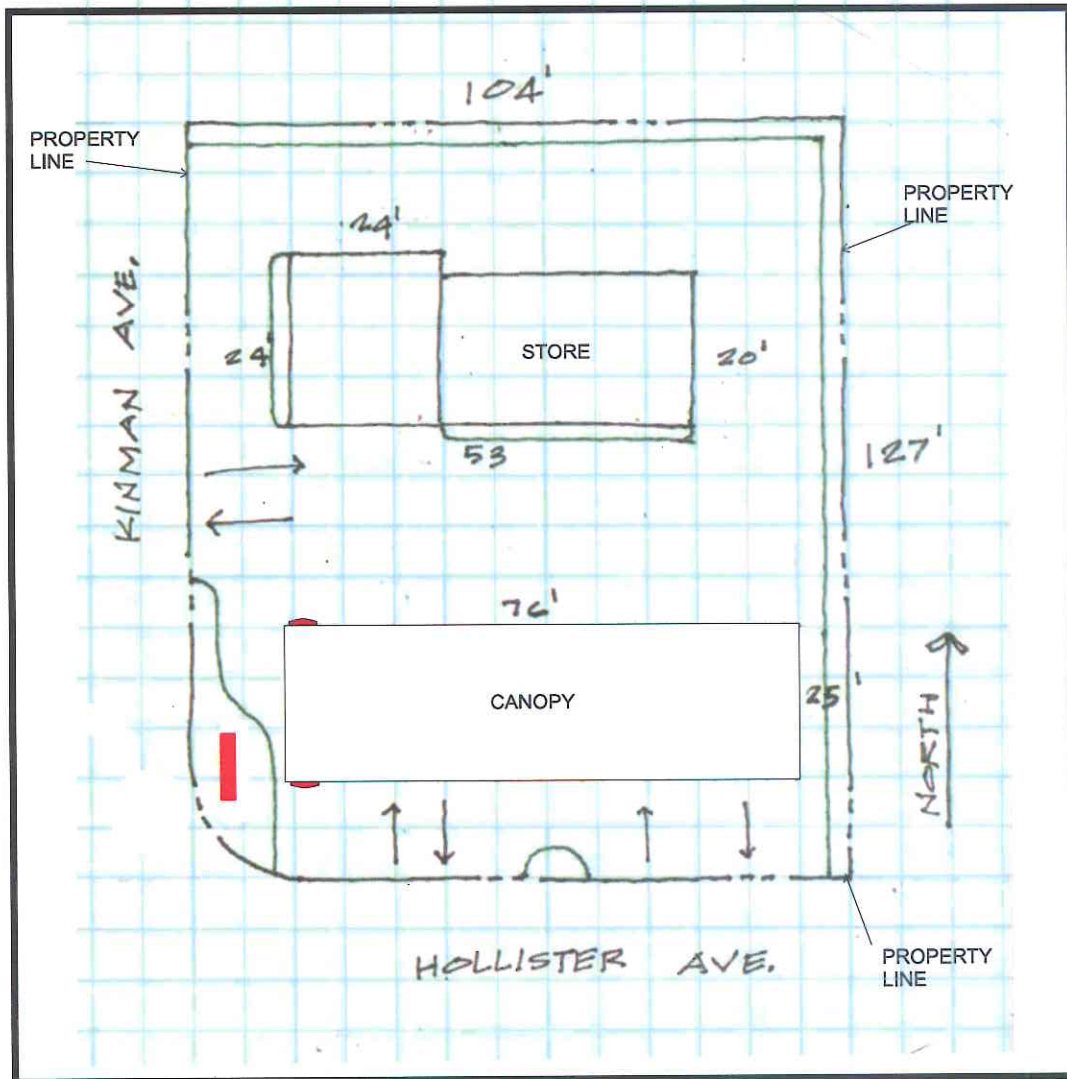

DRAWN YESSICA SANCHEZ
CHECKED
DATE 06-28-2010
SHEET TITLE CANOPY SIGN SPECS
JOB NO.
SHEET 6



LEGEND	
	= EXISTING SIGN
	= PROPOSED LOGO SIGN
	= DRIVEWAY
	= PROPERTY LINE

REVISIONS	BY
△	
△	
△	
△	
△	

PROMOTION PLUS
Providing the marketing you need!
 PH: 818-993-5406 / FX: 818-993-3174
 E-MAIL PERMITS@PROMOTIONPLUSINC.COM St. Lic. 863228

Signs & Service

PLEASE AUTHORIZE HERE X
 WITHOUT AUTHORIZATION PROMOTION PLUS IS UNABLE TO PROCESS YOUR ORDER.

LOCATION: _____
 REVISION #: _____
 Computer info: _____

DRAWN YESSICA SANCHEZ
CHECKED
DATE 06-28-2010
SHEET TITLE PLOT PLAN
JOB NO.
SHEET 7