



THIS DRAWING IS THE EXCLUSIVE PROPERTY OF BVA INC. THE INFORMATION SHOWN MAY NOT BE USED NOR THE DRAWINGS REPRODUCED WITHOUT BVA INC.'S WRITTEN CONSENT. COPYRIGHT © BALU VAIRAVAN ARCHITECTS INC., ALL RIGHTS RESERVED.

PROJECT  
**AUTOLIV ELECTRONICS NIGHT VISION**  
Office / Warehouse  
Interior Tenant Improvements  
420 South Fairview Ave  
Goleta, CA

TENANT  
**AUTOLIV ELECTRONICS NIGHT VISION**  
70B Castillon Drive  
Goleta, CA

REVISIONS	

11/02/09 PLANNING DEPT REVIEW  
DRAWING TITLE  
**SITE PLAN**  
BVA JOB #: 09-006

SCALE: 1" = 30'-0" DATE: 11/17/09

SHEET NUMBER:  
**SP-1**

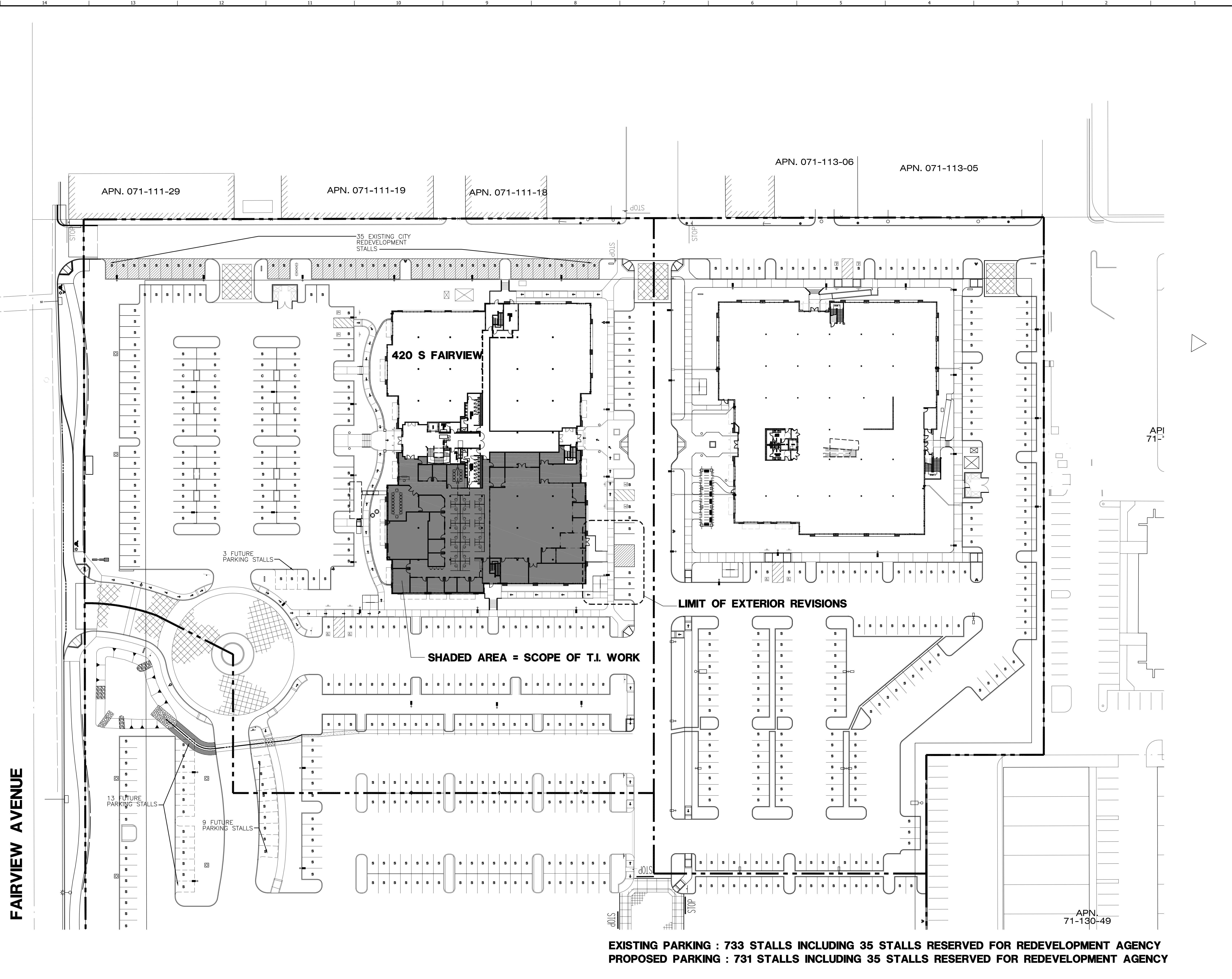

**FAIRVIEW AVENUE**

**EXISTING PARKING : 733 STALLS INCLUDING 35 STALLS RESERVED FOR REDEVELOPMENT AGENCY  
PROPOSED PARKING : 731 STALLS INCLUDING 35 STALLS RESERVED FOR REDEVELOPMENT AGENCY**

**EXISTING LANDSCAPING PERCENTAGE = 29.5%  
PROPOSED LANDSCAPE PERCENTAGE = (AFTER LOSS OF 224 SF) = 29.4%. NO LOSS OF EXISTING TREES**



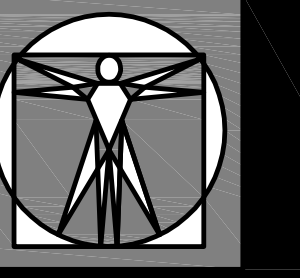

**AUTOLIV ELECTRONICS NIGHT VISION**

Office / Warehouse  
 Interior Tenant Improvements

420 South Fairview Ave  
 Goleta, CA

**AUTOLIV ELECTRONICS NIGHT VISION**

70B Castillon Drive  
 Goleta, CA

REVISIONS

No.	Description

DRAWING TITLE

**CONCEPTUAL SPACE PLAN**

BVA JOB #: 09-006

SCALE: 1/8" = 1'-0" DATE: 11/17/09

SHEET NUMBER:

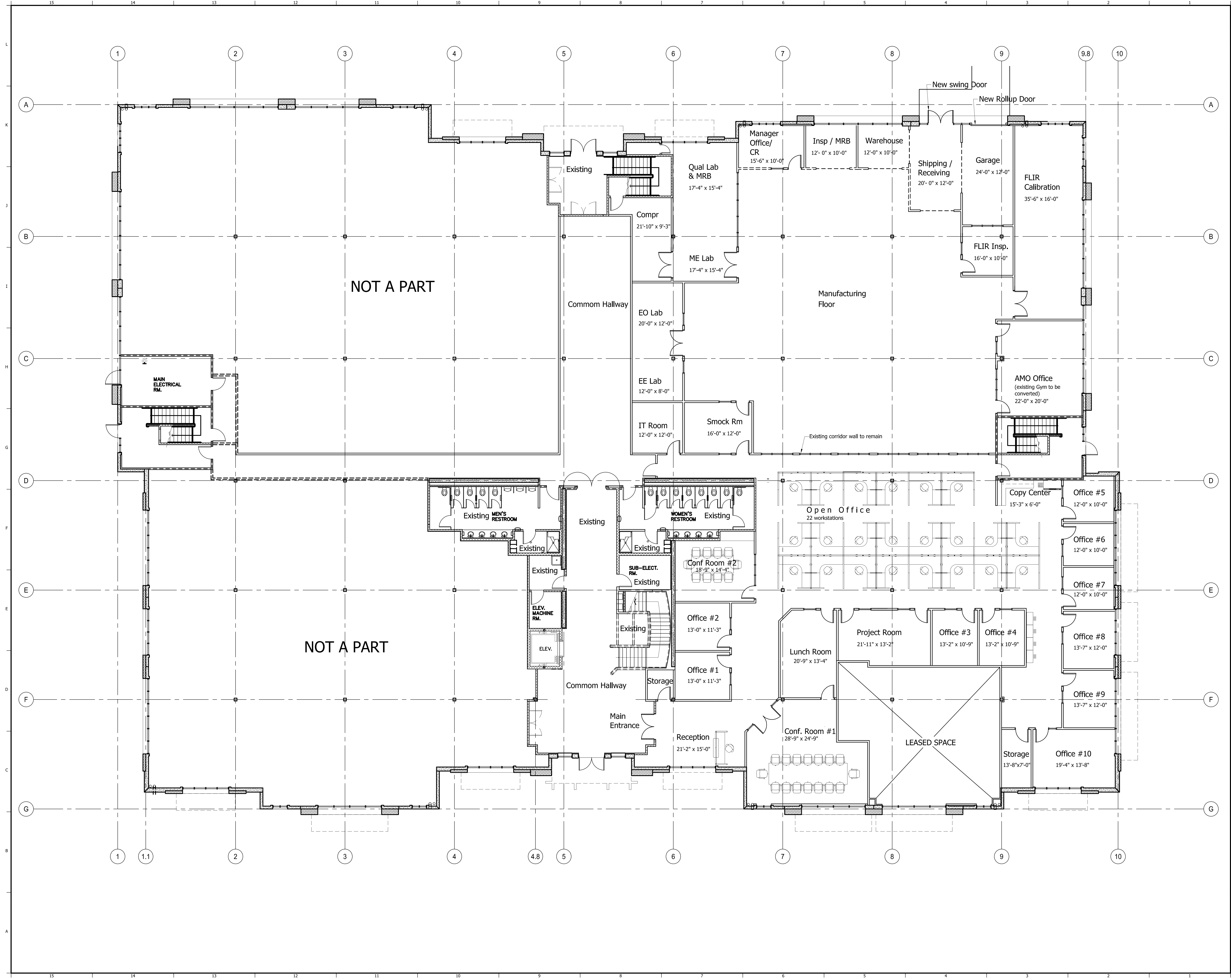

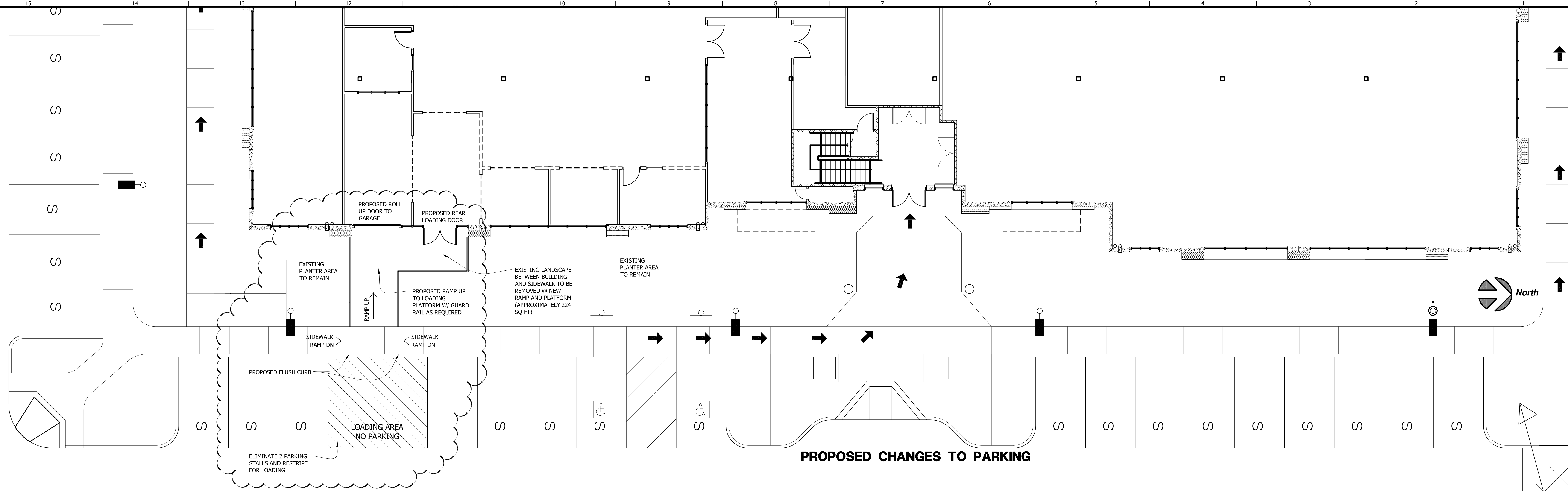

**PROPOSED CHANGES TO PARKING**



**EXISTING REAR ELEVATION**



**PROPOSED REAR ELEVATION**

NEW RAMP AT REAR DOORS  
 NEW GLASS ROLL UP DOOR  
 NEW ALUM/GLASS SWING DOOR  
 RECONFIGURED WINDOWS

SHADED AREA INDICATES SPANDEL GLASS, TO MATCH EXISTING SPANDEL GLASS  
 ALUMINUM FRAME TO BE ANODIZED BRONZE TO MATCH EXISTING DOOR/WINDOW FRAMES  
 GUARD RAIL AT RAMP TO BE PAINTED TO MATCH EXISTING BUILDING COLOR.

ARCHITECT

**bva**

Bala Vairavan Architects Inc.  
 4915 COLDWATER CANYON, STE 3  
 SHERMAN OAKS, CA 91423  
 TEL: (818) 205-7420

THIS DRAWING IS THE EXCLUSIVE PROPERTY OF BVA INC. THE INFORMATION SHOWN MAY NOT BE USED NOR THE DRAWINGS REPRODUCED WITHOUT BVA INC.'S WRITTEN CONSENT. COPYRIGHT © BALA VAIRAVAN ARCHITECTS INC. ALL RIGHTS RESERVED.

PROJECT

**AUTOLIV ELECTRONICS NIGHT VISION**  
 Office / Warehouse  
 Interior Tenant Improvements

420 South Fairview Ave  
 Goleta, CA

TENANT

**AUTOLIV ELECTRONICS NIGHT VISION**  
 70B Castillon Drive  
 Goleta, CA

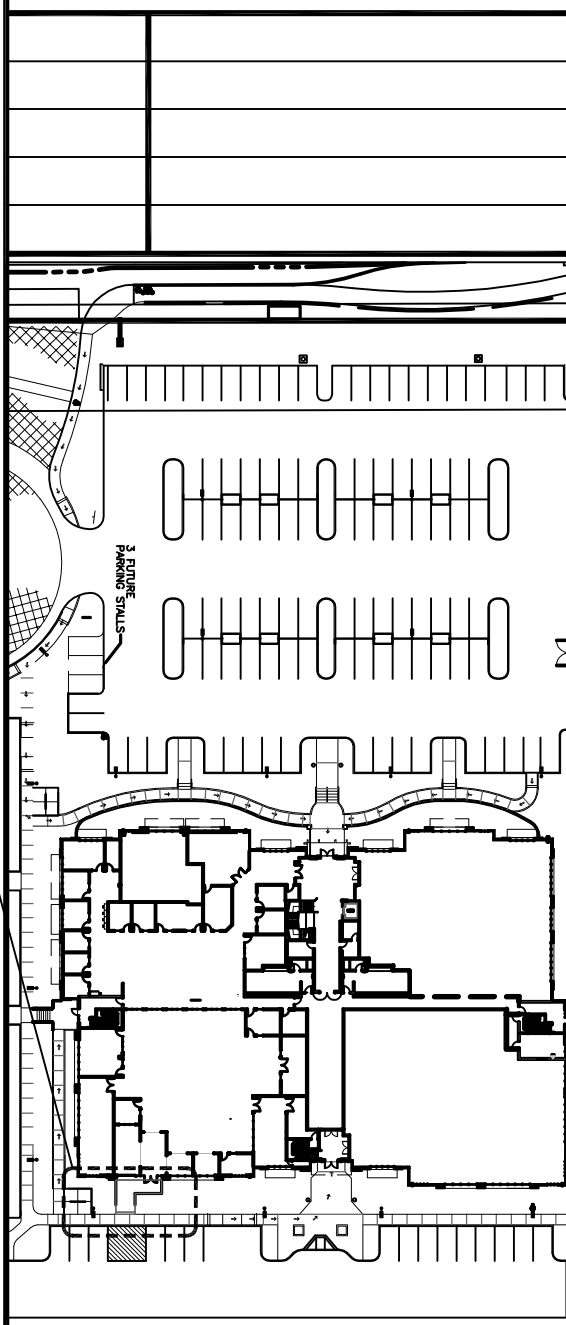

**KEY SITEPLAN**

REVISIONS

NO.	DATE	DESCRIPTION

11/02/09 PLANNING DEPT REVIEW

DRAWING TITLE

**REAR ELEVATION PROPOSED REVISIONS**

BVA JOB #: 09-006

SCALE: 1/8" = 1'-0" DATE: 11/17/09

SHEET NUMBER:

**EL-1**



# **bp** Glass Garage Doors

## **The Architect's Choice**

- High Strength Extrusions
- Custom Powder Coated Finishes
- Custom Tapered Sections
- Custom Glazing Options
- Custom Fabrication

**TOLL FREE**

**877-442-1716**

**bp** Bryce Parker Co. LIC # 750084



Phone: 626-442-1716 Fax: 626-579-5320  
www.GlassGarageDoors.com

9412 Gidley Street, Temple City, CA 91780  
Email: Service@bpcompany.net



# Overhead Door Checklist

(For Architects & Contractors)

The following checklist has been designed by Bryce Parker Company to assist Architects & Contractors with important design characteristics of an All Glass Garage Door. Diagrams have been provided (See Attachments) to illustrate key areas of focus. Should additional assistance be necessary, please contact us Toll Free (877) 442-1716.

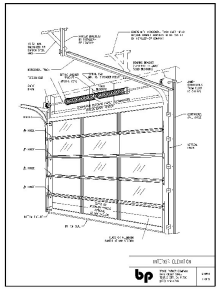

## Interior Elevation - (See Diagram #1 of 5)

Use this illustration to identify the following key design characteristics:

- Spring Pad (centered above header and made of solid backing; steel, concrete, or wood)
- Torsion Bar, Spring Assembly & Bearing Plates (fastened to spring pad and continuous jamb)
- Vertical & Horizontal Track (may not be obstructed in any way from floor to ceiling)
- Electric Operators Supply (1ea. 120v x 20 amp. receptacle mounted & located as per dia. #2 of 5)
- Back Hangers (supported above track from solid backing in ceiling, such as rafters)

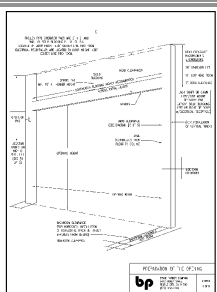

## Preparation of the Opening - (See Diagram #2 of 5)

Cross-reference your door opening with this diagram to note the following:

- Check that the header is flush with the jambs (Both should be on the same vertical plane)
- Available Head Clearance (of solid backing): \_\_\_\_\_ ft. \_\_\_\_\_ in. (Provide info to BP Co.)
- Available Jamb Clearance (of solid backing): \_\_\_\_\_ ft. \_\_\_\_\_ in. (Provide info to BP Co.)
- Opening Height: \_\_\_\_\_ ft. \_\_\_\_\_ in. (Provide info to BP Co.)
- Opening Width: \_\_\_\_\_ ft. \_\_\_\_\_ in. (Provide info to BP Co.)
- Side Clearance: \_\_\_\_\_ ft. \_\_\_\_\_ in. (Should not be obstructed ex. cabinets)
- Backroom Clearance (into room): \_\_\_\_\_ ft. \_\_\_\_\_ in. (Should not be obstructed ex. Cabinets)

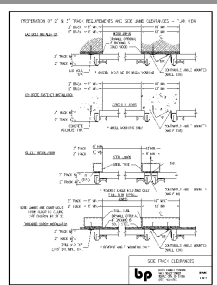

## Side Track Clearances - (See Diagram #3 of 5)

This page is mainly to illustrate the importance of the jamb area with regards to mounting the track. The additional weight of an all glass or aluminum sectional door must be supported properly by one of the following jamb types: (choose jamb type)

- Wood Jambs
- Concrete Jambs
- Steel Jambs
- Concrete & Steel Jambs

Note: It is acceptable for any of these jamb types to have drywall.

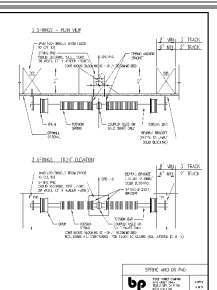

## Spring Anchor Pad Preparation - (See Diagram #4 of 5)

It is important to have solid backing in the header for the spring & electric operator assembly (including zero clearance installations). Since the number of springs and their configuration are determined at installation, it is important to design the spring pad for multiple configurations. The spring pad has a minimum requirement of 12" wide x Header Height (See Preparation Of The Opening Diagram #2). However, we recommend that you design a continuous spring pad (such as a structural header from jamb to jamb) to allow for multiple configurations.

- Spring Anchor Pad

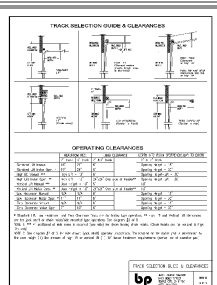

## Track Selection Guide - (See Diagram #5 of 5)

Using the information from Diagram #2 (Preparation of the Opening), you will be able to determine the appropriate track type for your opening.

- Standard Lift
- High Lift
- Roof Pitch
- Vertical Lift
- Low Headroom
- Zero Clearance

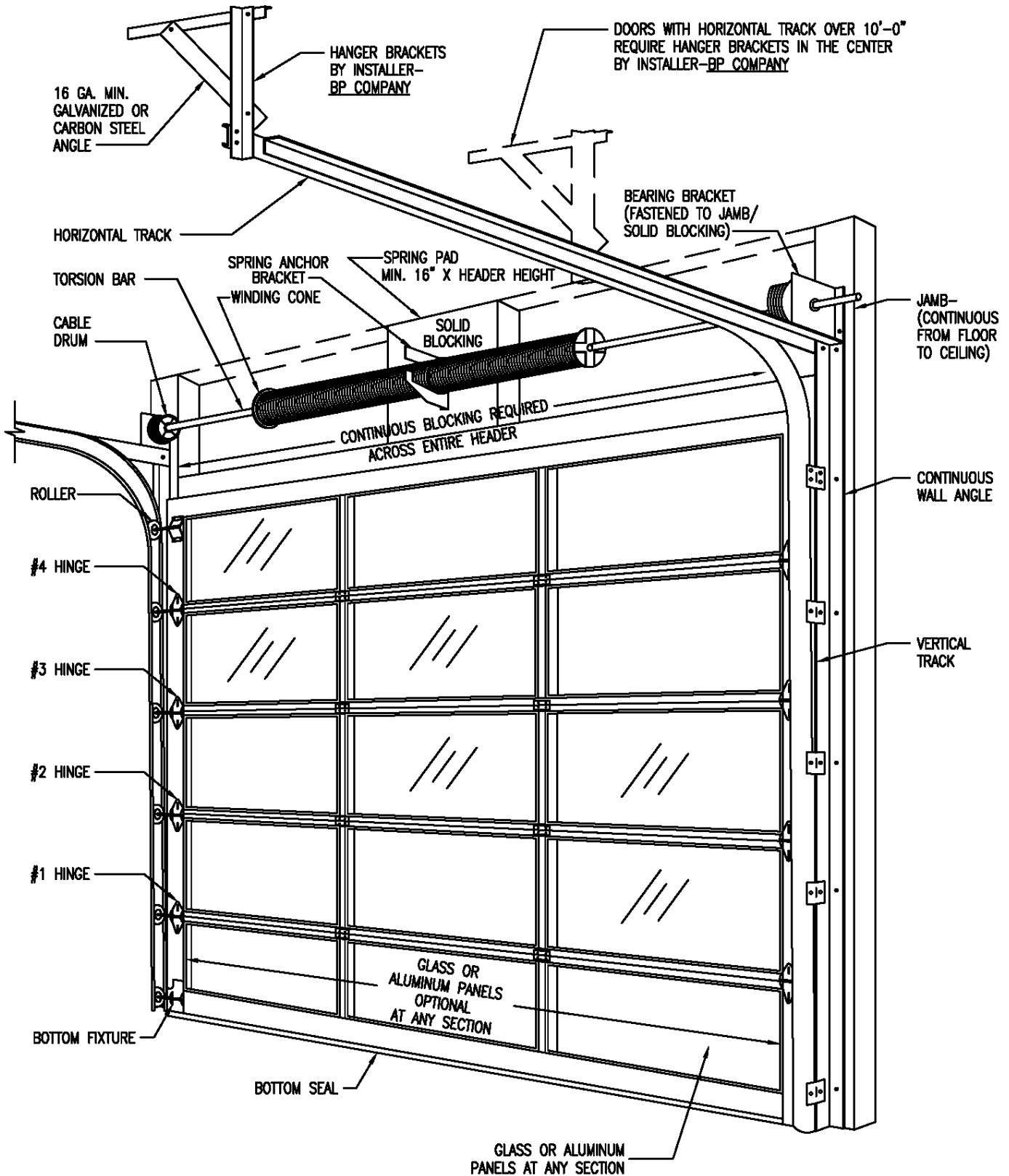

INTERIOR ELEVATION



BRYCE PARKER COMPANY  
 9412 GIDLEY STREET  
 TEMPLE CITY, CA 91780  
 (877) 442-1716

DRAWING  
 1 OF 5

TROLLEY TYPE OPERATOR PADS ARE 2' X 2' AND  
 MADE OF SOLID BLOCKING IN THE CEILING  
 LOCATED BY DOOR HEIGHT +30" CENTER LINE INTO ROOM  
 ELECTRICAL RECEPTACLES ARE LOCATED BY DOOR HEIGHT +36"  
 CENTER LINE INTO ROOM.

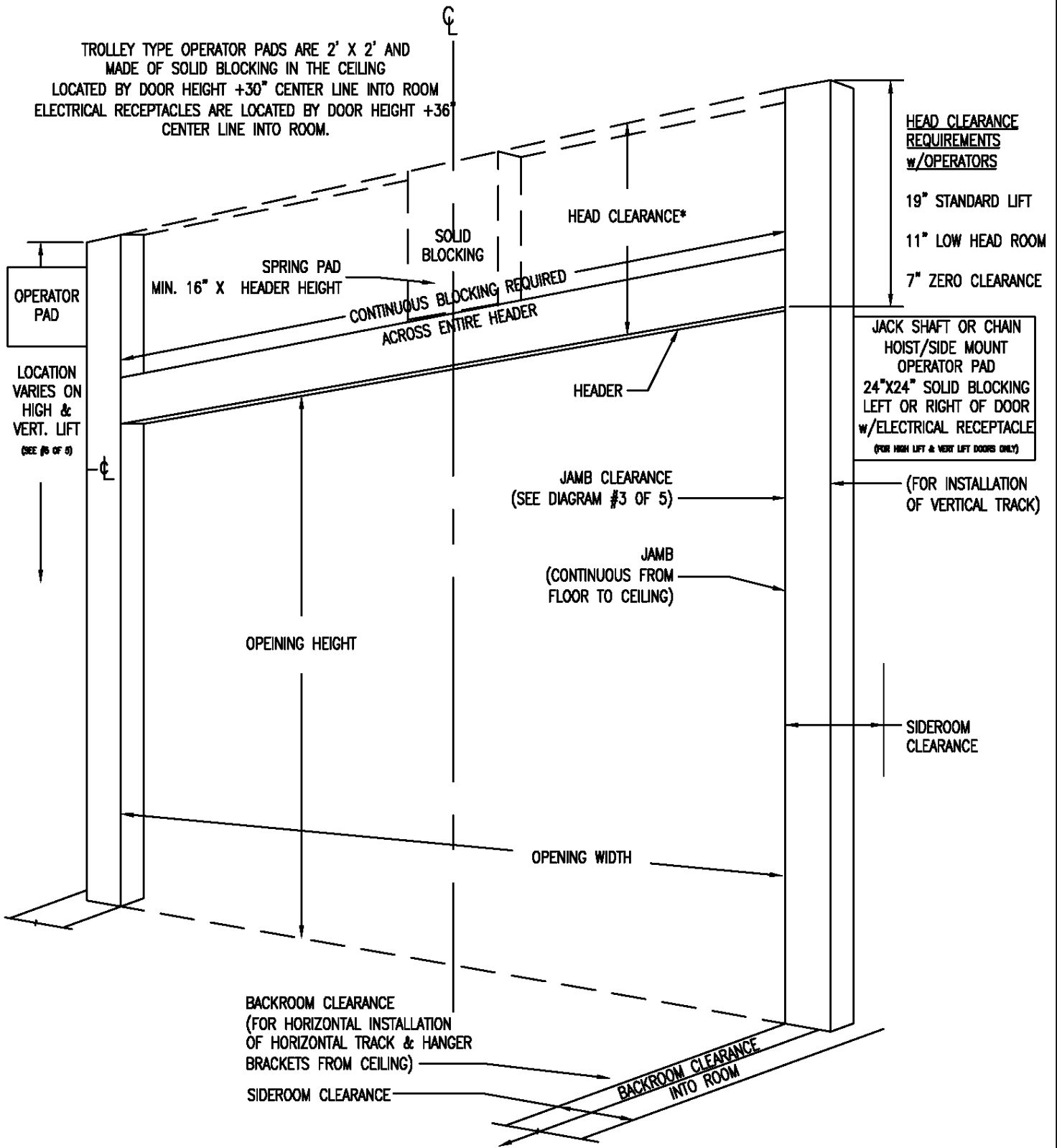

PREPARATION OF THE OPENING



BRYCE PARKER COMPANY  
 9412 GIDLEY STREET  
 TEMPLE CITY, CA 91780  
 (877) 442-1716

DRAWING  
 2 OF 5



PREPERATION OF 2" OR 3" TRACK REQUIREMENTS AND SIDE JAMB CLEARANCES - PLAN VIEW

LAG BOLT INSTALLATION

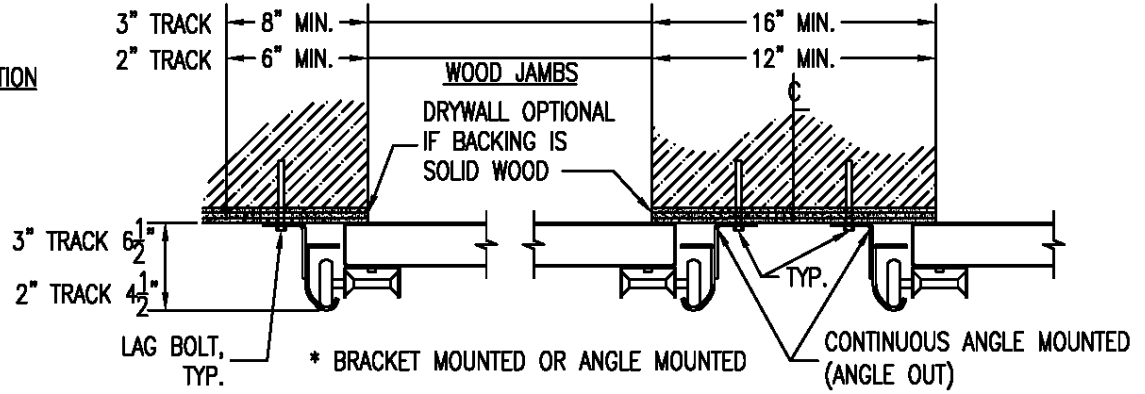

CONCRETE FASTENER INSTALLATION

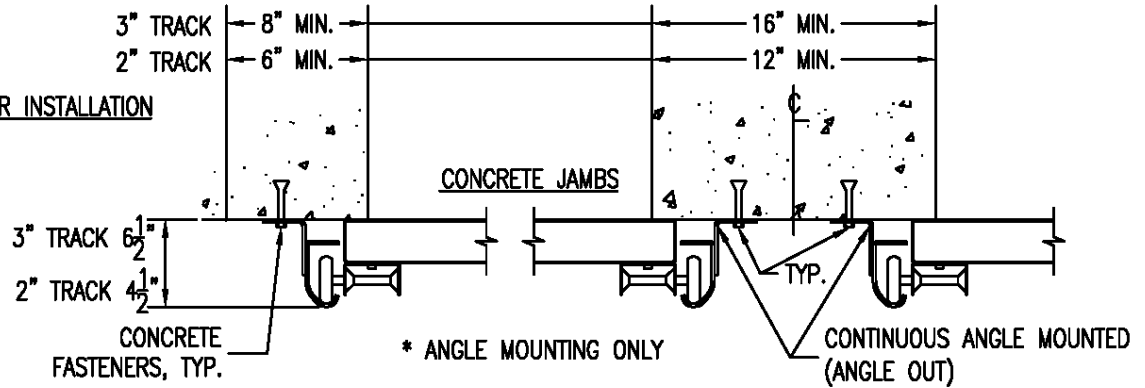

WELDED INSTALLATION

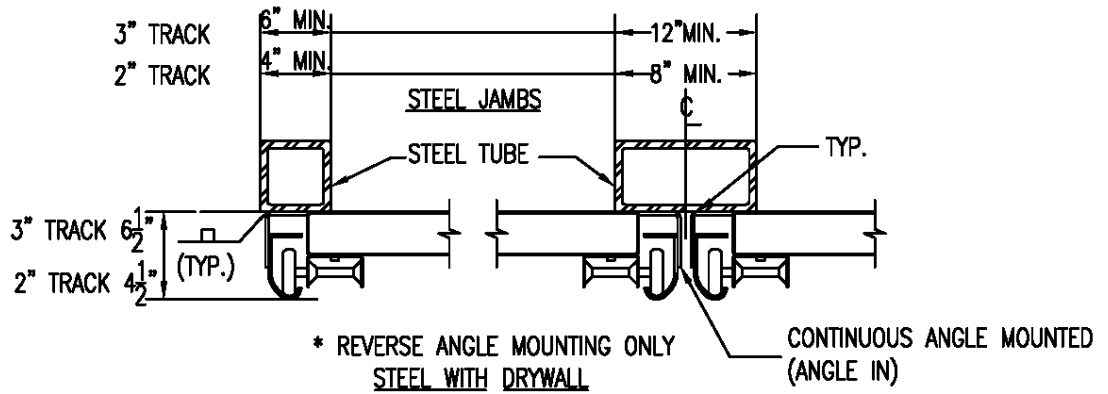

THREADED SCREW INSTALLATION

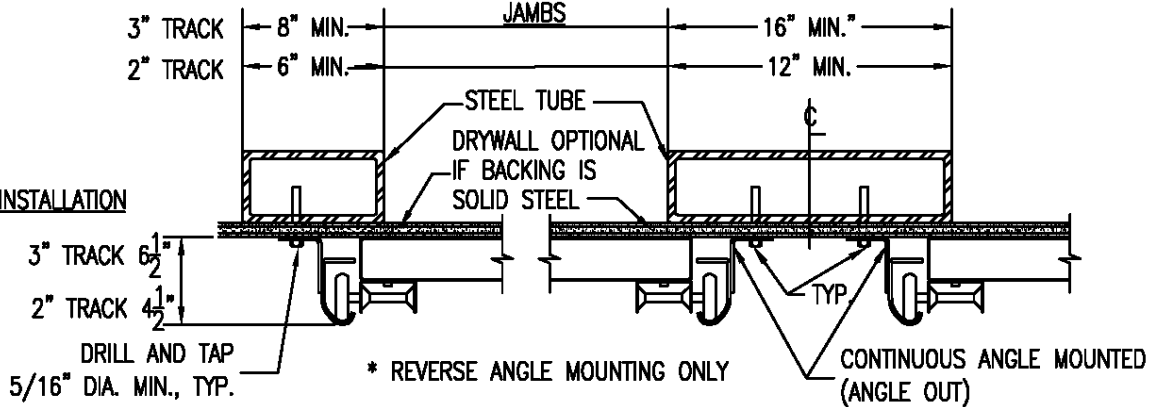

SIDE TRACK CLEARANCES



BRYCE PARKER COMPANY  
9412 GIDLEY STREET  
TEMPLE CITY, CA 91780  
(877) 442-1716

DRAWING  
3 OF 5

2 SPRINGS - PLAN VIEW

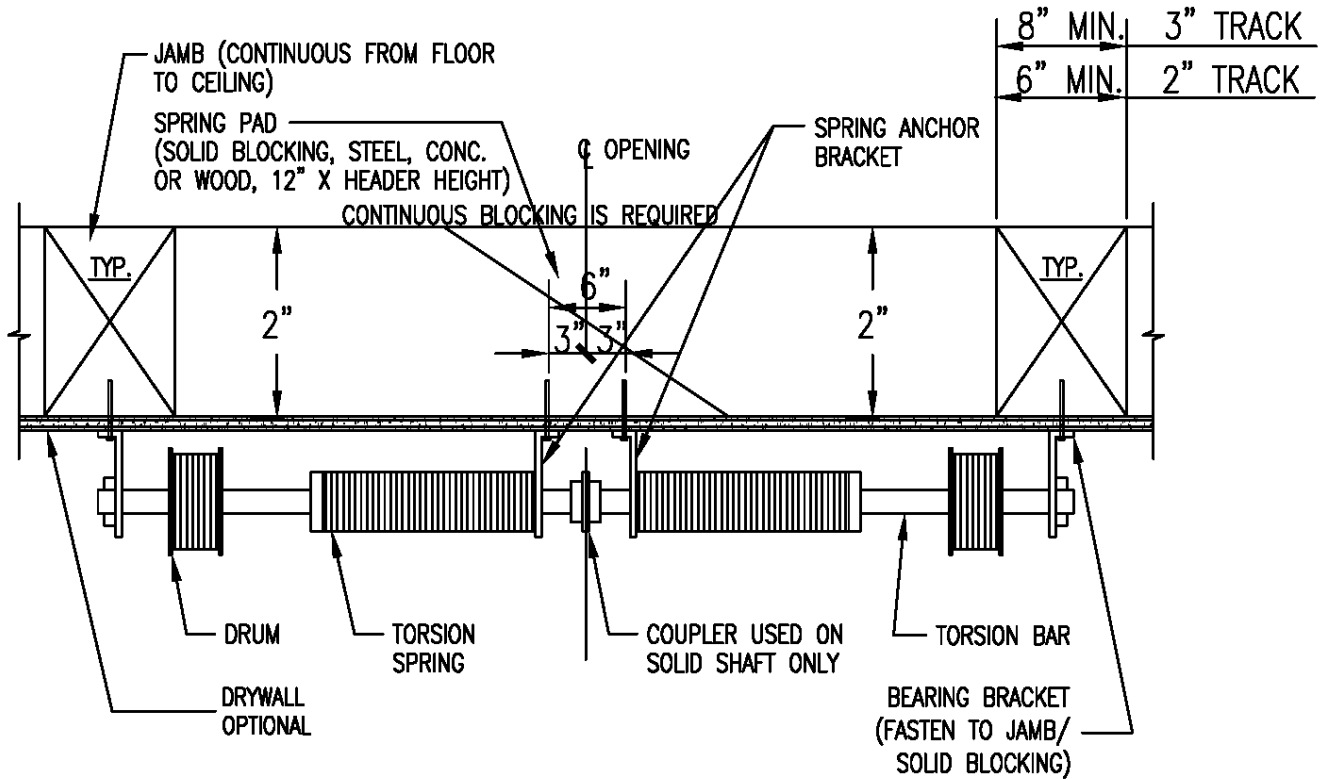

2 SPRINGS - FRONT ELEVATION

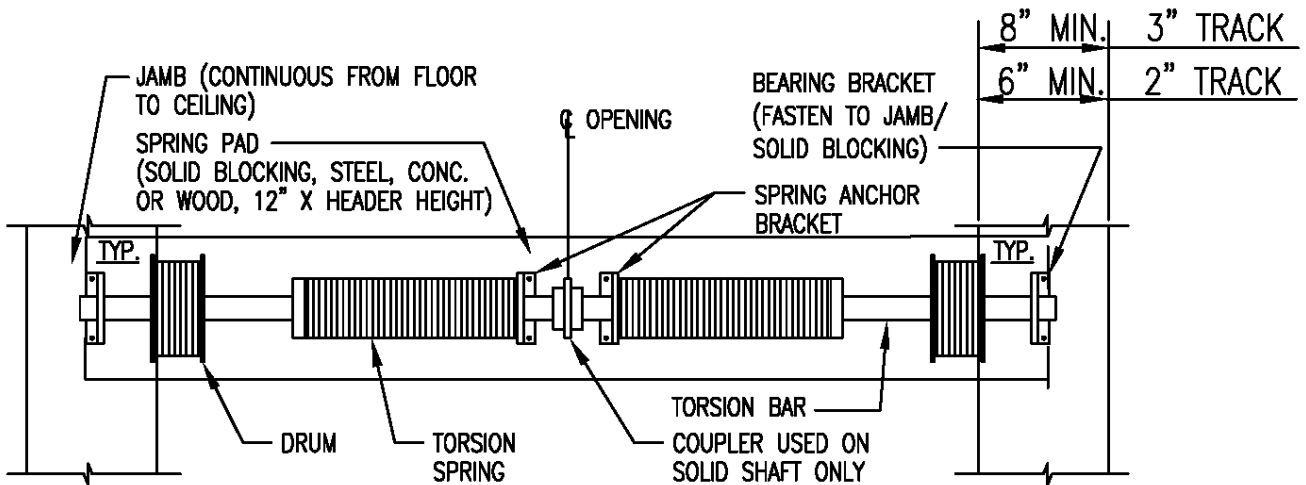

CONTINUOUS BLOCKING IS REQUIRED  
 NOTE: JAMBS ARE CONTINUOUS FROM FLOOR TO CEILING (SEE DIAGRAM #2 OF 5)

SPRING ANCHOR PAD



BRYCE PARKER COMPANY  
 9412 GIDLEY STREET  
 TEMPLE CITY, CA 91780  
 (877) 442-1716

DRAWING  
 4 OF 5

# TRACK SELECTION GUIDE & CLEARANCES

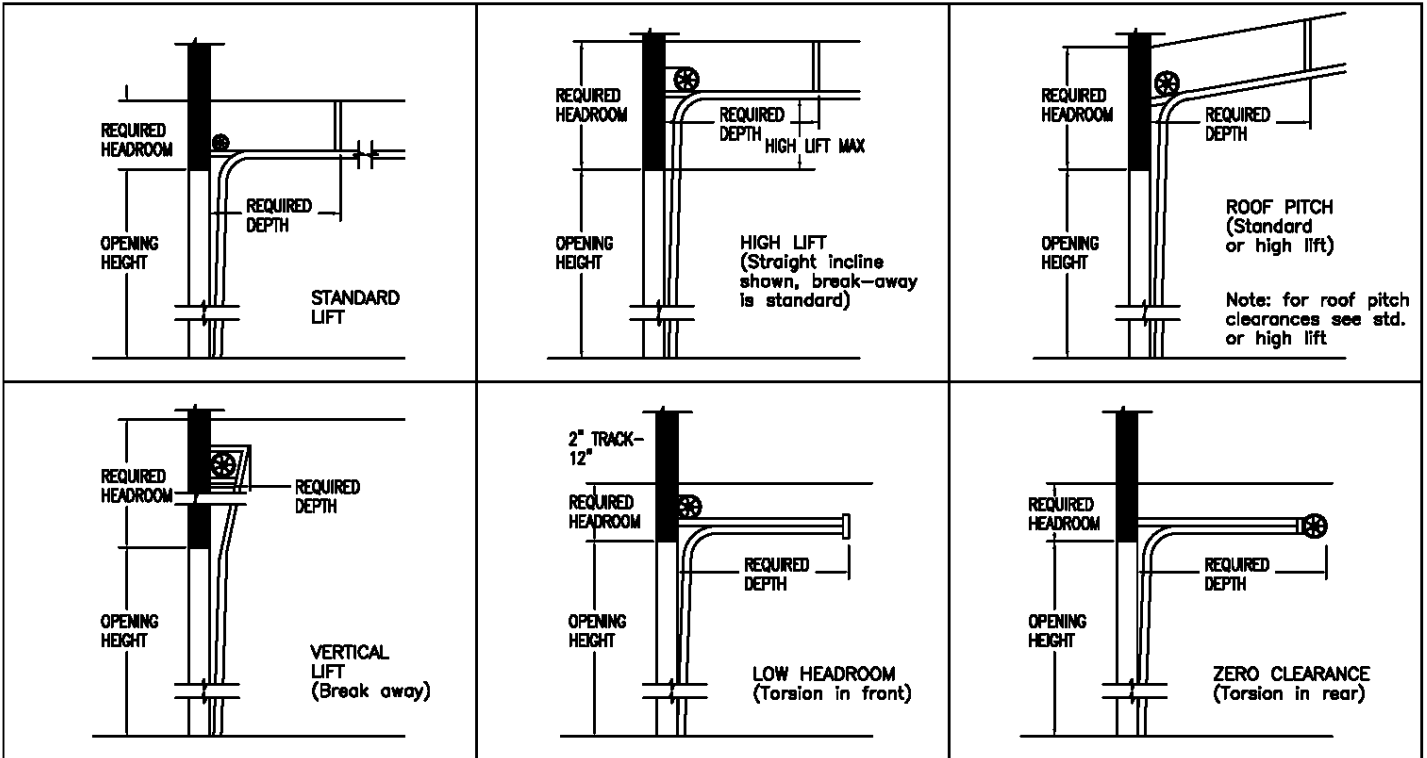

## OPERATING CLEARANCES

	HEADROOM REC.		SIDE ROOM		DEPTH INTO ROOM (PERPENDICULAR TO DOOR)
	2" Track	3" Track	2" Track	3" Track	2" & 3" Track
Standard Lift Manual	16"	21"	6"	8"	Opening Height + 18"
Standard Lift Motor Oper. *	19"	24"	6"	8"	Opening Height + 30"
High lift Manual ***	High Lift + 12"		6"	8"	Opening Height-Lift + 30"
High Lift Motor Oper. **	High Lift + 12"		24"x24" One side of header**		Opening Height-Lift + 30"
Vertical Lift Manual ***	Door Height + 18"		6"	8"	18"
Vertical Lift Motor Oper. **	Door Height + 18"		24"x24" One side of header**		18"
Low Headroom Manual	N/A	N/A	N/A	N/A	Opening Height + 18"
Low Headroom Motor Oper. *	11"	14"	6"		Opening Height + 30"
Zero Clearance Manual	N/A	N/A	N/A	N/A	Opening Height + 18"
Zero Clearance Motor Oper.	7"	10"	6"		Opening Height + 30"

\* Standard Lift, Low Headroom, and Zero Clearance Track are for trolley type operators.

\*\* High Lift and Vertical Lift clearances are for jack shaft or chain hoist/side mounted type operators. See diagram #2 of 5

\*\*\* 4" of additional side room is required (one side) for doors having chain hoists. (Chain hoists are for vertical & high lifts only)

NOTE 1: See diagram #2 of 5 for side mount (jack shaft) operator preparation. The location of the spring pad is determined by the door height (+) the amount of high lift or vertical lift (-) 18" below headroom requirements (center line of operator pad)

## TRACK SELECTION GUIDE & CLEARANCES



BRYCE PARKER COMPANY  
9412 GIDLEY STREET  
TEMPLE CITY, CA 91780  
(877) 442-1716

DRAWING  
5 OF 5



**bp - GLASS GARAGE DOORS & ENTRY DOORS**

A Division of Bryce Parker Co.

License Number. 750084

## ARCHITECTURAL SPECIFICATIONS

### bp - ALUMINUM & GLASS SECTIONAL GARAGE DOORS

**Manufactured for Shipment Across the entire USA**

**Factory Direct Installations Throughout CA, AZ, NV, FL & Optional In All Other States**

**Note: (Orders of 10 units or more require factory direct installation to validate warranty)**

- MANUFACTURER / GENERAL INFO.: **Models: BP- 350** (6 ft.-14ft. wide x 16 ft. high) & **BP- 450 HD** (14 ft.-24 ft. wide x 16 ft. high) Aluminum & Glass Sectional Garage Doors: Full Vision Type or Obscured Vision Type manufactured by **bp - Glass Garage Doors** in Temple City, CA - Toll Free (877) 442-1716 An established manufacturer with 55 years experience specializing in Glass Garage Doors
- METAL / FRAMES: All sections are constructed of **bp** - extruded aluminum alloy. The tensile strength is a minimum of 38 ksi, and approximately double the strength of standard 6063-T5 aluminum alloy. All rails are heat treated to maximum hardness as per Aluminum Association Standards. **Model BP- 350:** (6 ft.- 14 ft. wide x 16 ft. high) has a wall thickness of .080 inches **Model BP- 450 HD:** (14 ft.- 24 ft. wide x 16 ft. high) has a continuous wall thickness of .225 inches at key structural load points, an imbedded concealed stiffening strut at .135 inches, and auxiliary concealed stiffening struts at .250 inches for doors 17 ft.- 24 ft. wide.
- STILES AND RAILS: **Model BP- 350:** Top rails, bottom rails, and end stiles are 3-1/4 inches wide. **Model BP- 450 HD:** Top & Bottom rails are 5-3/8 inches wide and end stiles are 3-1/4 inch wide Horizontal meeting rails have a combined width of 2-3/4 inches. Vertical intermediate center mullions are 1-1/2 inches wide. 5/16 inch thru-bolts, nuts, and washers are used to rigidly secure all stiles and rails.
- FINISH: All rails are standard clear anodized at least 4 mills thick for a permanent luster finish. Powder coated colors must be chosen from the RAL European color standard. (Optional) (Custom paints and coatings will be considered & approved on an individual basis only)
- DOOR THICKNESS: 1-3/4 inches thick.
- JOINTS: All joints are mitered to form a tight and smooth fit with the door rails.
- COUNTER BALANCE: Galvanized torsion springs, head-plates, and center spring supports are mounted on a continuous galvanized torsion bar and calculated to exact weight and travel of each door. Cable drums are of die cast aluminum and are paired categorically for the track type specified. Lift cables are of high tension galvanized aviation type. (1/8 inch or 3/16 inch as req. by weight) Stainless Steel springs, and related hardware can be substituted in lieu of galvanized (Optional)
- TRACK: 2 inch x 15ga. galvanized continuous angle mounted (15 inch or 20 in. radius x 600lb max.) 3 inch x 12ga. galvanized continuous angle mounted (15 inch radius x 1200lb max.) 3 inch x 12ga. Stainless Steel continuous angle mounted (15 inch radius x 1400lb max) (Optional) All tracks are tapered to insure a weather-tight fit when in the closed position. (See "Track Selection Guide" for headroom requirements on drawing 5 of 5 to specify track type)



## **bp - GLASS GARAGE DOORS & ENTRY DOORS**

*A Division of Bryce Parker Co.*

License Number. 750084

- HINGES:** **bp** - Stainless Steel 12ga. universal and offset type, are graduated at each section to insure weather tight fit. **bp** - Stainless Steel hinges do not require lubrication. (Standard)
- ROLLERS:** 2 in. **bp** - Stainless Steel, polymer coated tire, sealed, 500 lb, precision bearing, roller (Standard)  
3 in. **bp** - Zinc dipped, rubber coated, sealed, 600 lb, precision bearing, roller (Standard)  
3 in. **bp** - Stainless Steel, polymer coated tire, sealed, 700 lb, precision bearing, roller (Optional)  
**bp** - Stainless Steel sealed rollers do not require lubrication. (Standard)
- WEATHER-STRIP:** A Santoprene gasket is applied at the factory the full length of the bottom section and at each end of the top rail where contact is made with the bumper spring.  
**bp** - Architectural perimeter weather-stripping is made of a three part extruded aluminum and Santoprene system, which conceals the fasteners with a snap cover. The **bp** - Architectural perimeter weather stripping can be exterior or interior mounted for a clean Architectural finish.
- OPERATORS:** Manual chain-hoists are compatible with standard, roof pitch, high-lift, and full vertical lift tracks  
Electric operation must be specified with the following: Push button station, key button station, and/or remote control operation. Auto reversing safety sensors are required for residential use and optional for most commercial applications. Operator specifications are per **bp - Glass Garage Doors** factory recommendations; based on weight, height, track type, and as required per code. (Note: Low headroom & zero-clearance track must be electronically operated for safety)
- GLAZING:** Glass, aluminum, or specialty panels ranging from: 1/16 in. - 1/4 in. / 1.5mm - 6mm thickness are encased in vinyl moldings, held in place by aluminum snap-in beads, and are designed to be easily removed and replaced in case of glass or panel breakage.  
(Note: 54 inch wide x 24 inch high maximum panel limits)
- GLASS SPECIFICATIONS:** Glass type must be specified with the following: Transparent or obscured frosted, tempered or laminated safety glass, and clear or color tinted hues (Visit us online to view glass panel samples)  
**Tempered Glass** meets the quality and strength requirements of ASTM C 1036 and ASTM 1048 for condition A, Quality q3, and Kind FT (Full Tempered). Tempered glass also meets the safety criteria of CPSC 16 CFR 1201 Categories 1 & 2, ANSI Z97.1, and qualifies as the glazing material for use in hazardous locations.  
**Laminated Safety Glass** (0.030 PVB or thicker interlayer with two lites of glass) also meets the safety criteria CPSC 16 CFR 1201 Categories 1 & 2, ANSI Z97.1, and ASTM C 1172 Standard Specifications for Laminated Architectural Flat Glass. 1/4" laminated glass has an STC of 35.
- OPTIONAL:** 1/8 in.- 1/4 in. custom glass panels, 1/16 in.- 1/4 in. aluminum or specialty panels, ventilation louvers, interior-mounted security bars, a variety of powder coated colors from the RAL color standard. 3 in. x 12ga. Stainless Steel track, springs, and related hardware can also be requested. Tapered top and/or bottom sections (for use when floor or header is out of square or sloping), custom panel locations, widths, and varying sections heights within the same door can also be accommodated to meet custom designs. Factory-Direct installations are provided in CA, AZ, NV, FL, and optional anywhere in the USA.

VIEW GLASS PANEL OPTIONS & ADDITIONAL INFORMATION ON THE WEB: [www.GlassGarageDoors.com](http://www.GlassGarageDoors.com)

# bp Glass Garage Doors

## "The Architect's Choice"

### bp Advantages (Our Door)



### Competitors' Disadvantage (Competitor Door)



- **BP- Aluminum Alloy:** High tensile strength at 38 ksi and double the rigidity of standard alloy.
- **Standard (6063) Aluminum Alloy:** Much weaker and 1/2 the tensile strength of BP - Aluminum Alloy.
- **Narrow Intermediate Mullions:** Cleaner architectural lines, showing more glass and less structure.
- **Wide Intermediate Mullions:** Shows less glass, more frame, and is visually less appealing (See above, marked by arrows).
- **Heavier Wall Thickness:** Allows for more weight and wider glass panels, without deflection. (Ex. Our door has 250 lbs of aluminum vs. a competitor's 100 lbs.)
- **Thinner Wall Thickness:** Causes vertical and horizontal deflection, which requires stiffening struts that can be seen through the glass. (See above, as marked by red arrows)
- **Factory Direct Manufacturing Speed:** By strictly focusing on Glass Garage Doors and Entry Doors, our manufacturing time is the best in the industry.
- **Not Factory Direct:** Orders are placed through a distributor, and can take 6-10 weeks.
- **Factory Direct Installation (CA, AZ, NV, FL & Optional in all other states):** A factory specified installation produces a smoother and longer lasting garage door.
- **Not Factory Installation:** An installer other than the factory may not have the expertise or take the time needed to meet a factory specified installation.
- **Customization:** Our customers can request specific panel sizes, quantities, height of each section, tapered bottom / top sections, and reveal of frame around the door.
- **Limited Customization:** Our competitors are not set up to accommodate customers' special requests.
- **Complementing Entry Doors:** We can manufacture Entry Doors and Side Gates with single or multiple glass panels to match your Glass Garage Door. Custom Lock hardware can also be accommodated.
- **No Complementing Entry Doors:** Our competitors are not set up to accommodate customers' special requests.

- ➡ **Stainless Steel 11-gauge Hinges:** Laser cut, heavy duty hinges for an extra clean Architectural finish. Note: Stainless Hinges do not require lubrication.
- ➡ **Standard Mild Steel Hinges:** Thinner 14 to 18 gauge galvanized hinges are weaker, may break under typical glass weights, and require constant lubrication.
- ➡ **Stainless Steel Rollers:** Heavy Duty, sealed, water resistant rollers of 500lb load capacity each, with no lubrication required.
- ➡ **Standard Metal or Nylon Rollers:** 50lb. load capacity each, non sealed, and require constant lubrication.
- ➡ **Zinc Plated or Stainless Steel Springs:** Rust resistant and do not require lubrication.
- ➡ **Standard Springs:** Raw oil tempered springs rust and require constant lubrication.
- ➡ **Concealed Stiffening Struts:** Stronger, lighter, and are hidden as part of the door rail, which won't be seen from the outside.
- ➡ **Standard Metal Struts:** Weak, heavy, surface mounted, and can be seen through glass. (See above, marked by arrows).
- ➡ **Custom Glass and Frame Colors:** Over 200 types of custom glass, powder coated colors, and panels to choose from.
- ➡ **Limited Glass and Color Options:** A few standard glazing types and color options.
- ➡ **Architectural Weather Stripping:** Made from 3 part extruded aluminum, commercial Santoprene, and installed with concealed fasteners.
- ➡ **Typical Residential Weather Stripping:** Made entirely of poor quality vinyl with exposed nails which rust.
- ➡ **Custom Tapered Sections:** Top and/or bottom sections/panels for out of square driveways and openings. (See picture gallery)
- ➡ **Standard Rectangular Sections:** May otherwise leave large gaps at the floor and header.
- ➡ **Commercial Duty Hardware:** High capacity, long lasting, with minimum lubrication or service required.
- ➡ **Standard Residential Hardware:** Low capacity , which wears out quickly; requiring constant lubrication, and costly service calls.
- ➡ **Extremely Quiet Operation:** Due to the use of premium components, noise-causing friction is dramatically reduced.
- ➡ **Typical Noisy Operation:** Attributed to cheap components, and out of square track; which cause friction and costly repairs.
- ➡ **What Makes bp the best:** In addition to the reasons above, proprietary fabrication methods and classified materials have been incorporated to produce our highly regarded glass doors.
- ➡ **Why Others Can't Compare:** Manufacturers that mass-produce a wide variety of other types of doors are catering to a less discriminating market. In most cases, quality is compromised for quantity.

**You get what you pay for!** Quality engineered and tested designs for over 55 years in business!

---

### The Experience :

Purchasing a sectional garage door from us is just a lot simpler. We manufacture, install, and warranty our own product.

**Powder Coating Color Chart**



NOTE: RAL is the most popular Central European Color Standard used today. The colors in this chart are **ONLY** displayed to give an overview of the colors available. This chart is a reproduction of the RAL color standard printed from [www.tigerdrylac.com](http://www.tigerdrylac.com). Variations in computer monitors, video cards and color printers will cause variations from the actual colors. This chart is to be used as a guide for color planning and specification only.



# **bp** *Glass Garage Doors*

## *Special Effect Powder Coating Options*

				
<b>9007/205</b>	<b>9017/201</b>	<b>9017/209</b>	<b>9018/201</b>	<b>9018/206</b>
				
<b>9026/202</b>	<b>9044/201</b>	<b>9052/201</b>	<b>9052/202</b>	<b>9053/202</b>
				
<b>9053/204</b>	<b>9061/201</b>	<b>9090/201</b>	<b>9104/202</b>	<b>9104/205</b>
				
<b>9104/206</b>	<b>9107/201</b>	<b>9128/202</b>	<b>9154/201</b>	<b>9152/204</b>

# **bp** *Glass Garage Doors*

## *Special Effect Powder Coating Options*

						
<b>9835/005</b>	<b>51263-031</b>	<b>51439-013</b>	<b>51701-002</b>	<b>51712-021</b>	<b>51932-001</b>	<b>52009-003</b>
						
<b>90383-001</b>	<b>94861-021</b>	<b>94862-001</b>	<b>98435-001</b>	<b>98789-011</b>	<b>98795-001</b>	

				
<b>9035-403</b>	<b>9035-405</b>	<b>9035-406</b>	<b>9057-401</b>	<b>9065-401</b>
				
<b>9070-401</b>	<b>9105-402</b>	<b>9105-404</b>	<b>9105-405</b>	<b>9132-401</b>