

Accessibility Requirements

APPLICATION:

Accessibility to public buildings, commercial buildings and publicly funded housing. Group occupancies included are A, B, E, F, H, I, M, R (hotels, motels, Inn, dormitories, resorts, homeless shelters, halfway houses, transient group homes and similar places of transient lodging), S, and outdoor occupancies, such as parks and recreational areas, campsites, beach picnic areas, boat docks, and nature trails. For application to privately funded housing, refer to Chapter 11-A of the 2001 California Building Code, Volume 1.

CODE REFERENCE: CALIFORNIA BUILDING CODE, VOLUME 1, CHAPTERS 10 AND 11B

AN IMPORTANT NOTE:

The contents of all illustrations of this bulletin are taken from the 2001 California Building Code, Volume 1, Chapters 10 and 11B. The users of this bulletin should be aware that this bulletin is intended only as an aid to the basic understanding of the regulations and that to fully understand and apply these regulations, they must refer to the code reference stated above.

NEW BUILDINGS

GENERAL CONCEPT:

Provide path of travel from handicapped parking spaces to all accessible elements and spaces, such as walks, sidewalks, curb ramps and pedestrian ramps, lobbies and corridors, elevators, sanitary facilities, other improved areas or necessary combinations thereof that provide free and unobstructed access to and from a particular area or location for pedestrians and/or wheelchair users.

ILLUSTRATION OF ACCESSIBILITY REGULATIONS

ACCESSIBLE PARKING:

Handicapped parking spaces shall be located on the shortest accessible route to an accessible entrance and they shall be so arranged that persons with disabilities are not compelled to wheel or walk behind parked cars other than their own. The required number of handicapped parking spaces shall be in accordance with table below.

TOTAL REQUIRED	MINIMUM HANDICAPPED SPACES REQUIRED
1 to 25	1 van accessible space
26 - 50	2 including 1 van accessible space
51 - 75	3 including 1 van accessible space
76 - 100	4 including 1 van accessible space
101 - 150	5 including 1 van accessible space
151 - 200	6 including 1 van accessible space
201 - 300	7 including 1 van accessible space
301 - 400	8 including 1 van accessible space
401 - 500	9 including 2 van accessible spaces
501 - 1000	2% including 3 van accessible spaces
1001 - ?	20 + 1 per 100 or fraction, including min. 1 van accessible space per 8 accessible spaces or fraction thereof

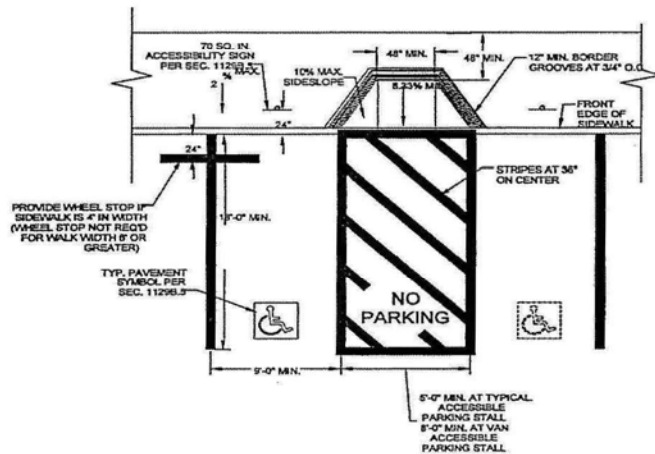

THIS DIAGRAM ILLUSTRATES THE SPECIFIC REQUIREMENTS OF THESE REGULATIONS AND IS INTENDED ONLY AS AN AID FOR BUILDING DESIGN AND CONSTRUCTION

SINGLE PARKING STALLS

ABSTRACT OF REQUIREMENTS FOR THE PHYSICALLY HANDICAPPED

REFERENCE: CALIFORNIA BUILDING CODE
CHAPTER 11-B

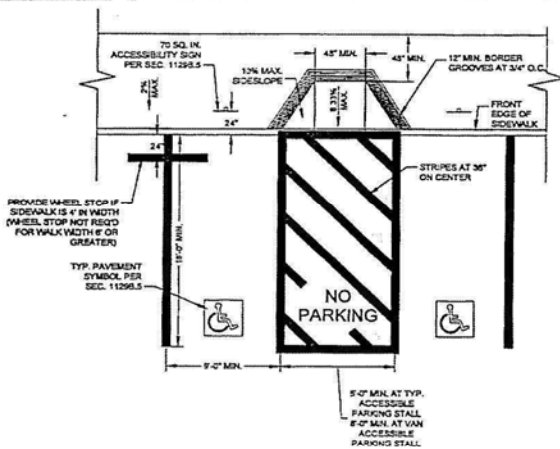

THIS DIAGRAM ILLUSTRATES THE SPECIFIC REQUIREMENTS OF THESE REGULATIONS AND IS INTENDED ONLY AS AN AID FOR BUILDING DESIGN AND CONSTRUCTION

DOUBLE PARKING STALLS

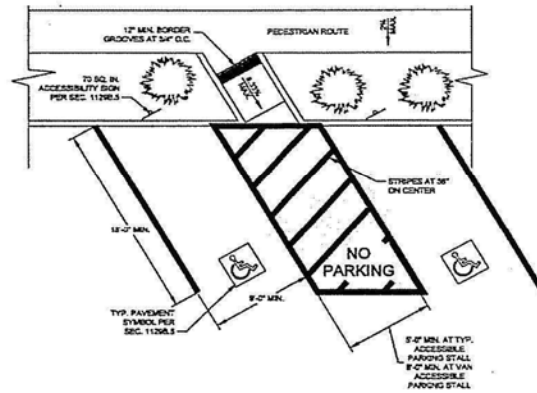

THIS DIAGRAM ILLUSTRATES THE SPECIFIC REQUIREMENTS OF THESE REGULATIONS AND IS INTENDED ONLY AS AN AID FOR BUILDING DESIGN AND CONSTRUCTION

DIAGONAL PARKING STALLS

EXTERIOR ROUTES OF TRAVEL:

From handicap parking spaces, provide most practical direct accessible route of travel to all building entrances and exterior ground level exits by incorporating pedestrian ramps, walks, and sidewalks. Any path of travel will be considered a ramp if its slope is greater than 1:20 (5 percent) of horizontal run.

WALKS AND SIDEWALKS REQUIREMENTS:

- Width = 48"
- Slope = 1 in 20 max.
- Change in level = Max 1/2", 1/4" - 1/2" beveled (1:2) 1 vertical to 2 horizontal
- Cross slope = Max 1/4" per foot
- Level areas at doors and gates = 60" x 60" swing side and 48" wide x 44" deep on push side
- Swing side strike edge clearance = 24"
- Hand rail not required

RAMP REQUIREMENTS:

- Width = As required for stairways and exits and min 48"
- Slope = Max 1:12 (1:14 or less preferred)
- Cross slope = Max 1:50
- Landing = See illustration below
- Hand rail = Required with slope >1:20
- Hand rail height = 34" to 38"
- Hand rail grip = 1 1/2" diameter

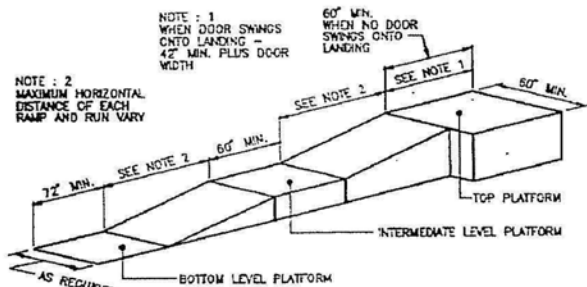

(a) STRAIGHT RAMP RUN

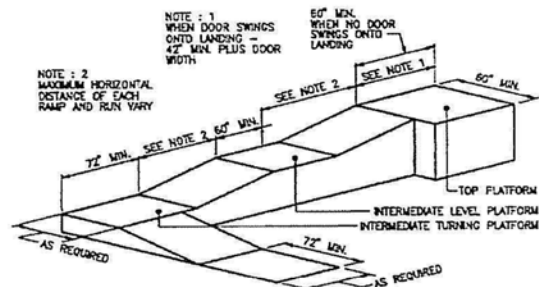

(b) RAMP WITH TURNING PLATFORM

THIS DIAGRAM ILLUSTRATES THE SPECIFIC REQUIREMENTS OF THESE REGULATIONS AND IS INTENDED ONLY AS AN AID FOR BUILDING DESIGN AND CONSTRUCTION

RAMP DIMENSIONS

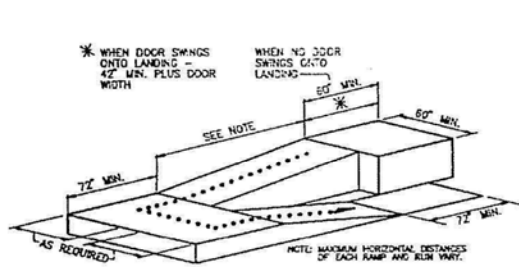

(a) RAMP WITH INTERMEDIATE SWITCH-BACK PLATFORM

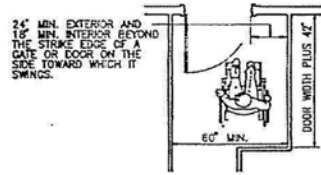

(b) RAMP LANDING AT DOORWAY

THIS DIAGRAM ILLUSTRATES THE SPECIFIC REQUIREMENTS OF THESE REGULATIONS AND IS INTENDED ONLY AS AN AID FOR BUILDING DESIGN AND CONSTRUCTION

RAMP LANDING AND DOORWAY

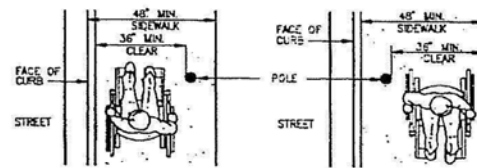

(a) SIDEWALK OBSTRUCTIONS

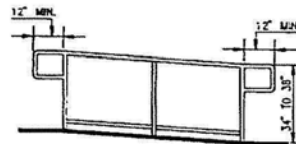

(b) GUIDE RAIL

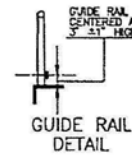

GUIDE RAIL CENTERED AT 3\"/>

GUIDE RAIL DETAIL

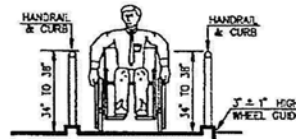

(c) WHEEL GUIDE

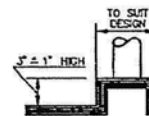

WHEEL GUIDE DETAIL

THIS DIAGRAM ILLUSTRATES THE SPECIFIC REQUIREMENTS OF THESE REGULATIONS AND IS INTENDED ONLY AS AN AID FOR BUILDING DESIGN AND CONSTRUCTION

RAMP AND SIDEWALKS

STAIRWAYS:

Construction of stairway shall comply with the standards stated below regardless of whether access is provided via elevators.

HANDRAILS:

- Height = 34" - 38"
- Extension at top = 12" past top nosing
- Extension at bottom = 12" + tread width
- Mounting = 1 1/2" space from wall
- Grip = 1 1/4" - 1 1/2" or equivalent shape
- Risers = open risers are not permitted

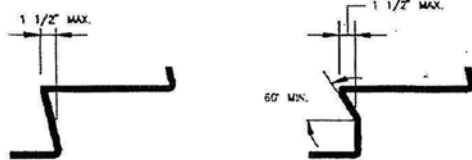

STAIRS

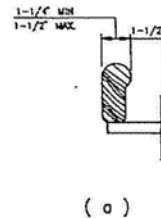

(a)

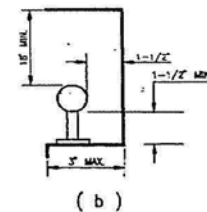

(b)

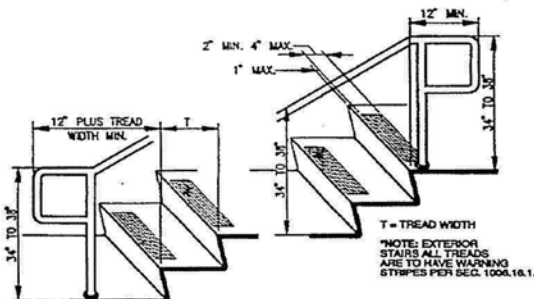

THIS DIAGRAM ILLUSTRATES THE SPECIFIC REQUIREMENTS OF THESE REGULATIONS AND IS INTENDED ONLY AS AN AID FOR BUILDING DESIGN AND CONSTRUCTION

WARNING STRIPING AND HANDRAIL EXTENSIONS

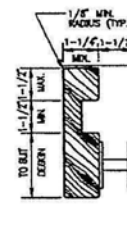

(c)

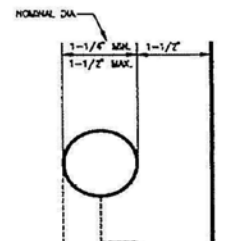

(d)

THIS DIAGRAM ILLUSTRATES THE SPECIFIC REQUIREMENTS OF THESE REGULATIONS AND IS INTENDED ONLY AS AN AID FOR BUILDING DESIGN AND CONSTRUCTION

STAIR HANDRAILS

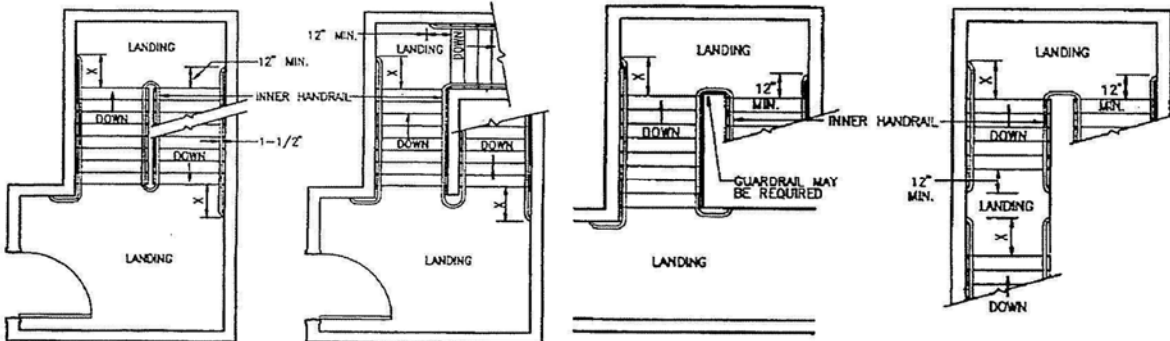

NOTE: INNER HANDRAIL AT LANDINGS OF STAIRS THAT DOUBLE BACK OR IMMEDIATELY TURN SHALL BE CONTINUOUS AND SHALL NOT EXTEND INTO LANDINGS OR PATH OF TRAVEL.

X: EXTENSION OF HANDRAIL SHALL BE EQUAL TO THE TREAD WIDTH PLUS 12 INCHES.

THIS DIAGRAM ILLUSTRATES THE SPECIFIC REQUIREMENTS OF THESE REGULATIONS AND IS INTENDED ONLY AS AN AID FOR BUILDING DESIGN AND CONSTRUCTION

STAIR HANDRAILS

DOORS:

All entrances and exterior and interior exit doors regardless of the occupant load shall be made accessible to persons with disabilities.

Size = Min 3'-0" wide (32" clear when 90° open) and 6'-8" in height

Door hardware = operable with single effort without requiring ability to grasp hardware

Effort to operate doors = 8 1/2 pounds at exterior doors and 5 pounds at interior doors

Door hardware height = 30" - 44" above floor

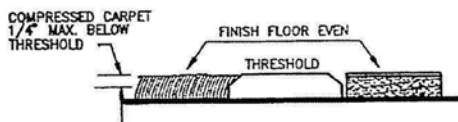
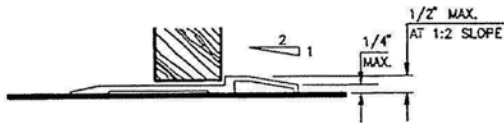

THIS DIAGRAM ILLUSTRATES THE SPECIFIC REQUIREMENTS OF THESE REGULATIONS AND IS INTENDED ONLY AS AN AID FOR BUILDING DESIGN AND CONSTRUCTION

THRESHOLDS

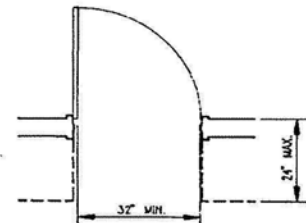

(a) HINGED DOOR



(b) SLIDING DOOR



(c) FOLDING DOOR

THIS DIAGRAM ILLUSTRATES THE SPECIFIC REQUIREMENTS OF THESE REGULATIONS AND IS INTENDED ONLY AS AN AID FOR BUILDING DESIGN AND CONSTRUCTION

CLEAR DOOR WIDTH AND DEPTH

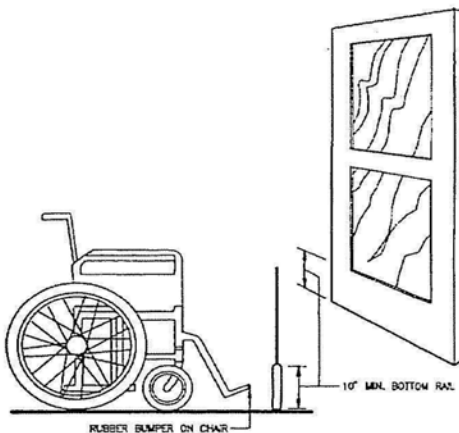

THIS DIAGRAM ILLUSTRATES THE SPECIFIC REQUIREMENTS OF THESE REGULATIONS AND IS INTENDED ONLY AS AN AID FOR BUILDING DESIGN AND CONSTRUCTION

DOOR CONSTRUCTION

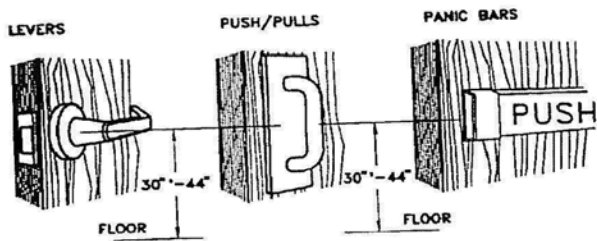

THIS DIAGRAM ILLUSTRATES THE SPECIFIC REQUIREMENTS OF THESE REGULATIONS AND IS INTENDED ONLY AS AN AID FOR BUILDING DESIGN AND CONSTRUCTION

DOOR HARDWARE

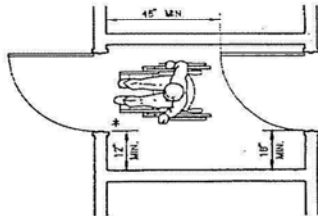

(a) DOOR IN SERIES

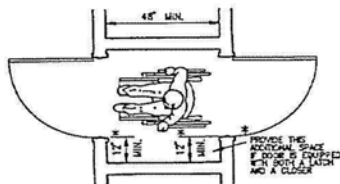

(b) BOTH DOORS OPEN OUT

(SERVING OTHER THAN A REQUIRED EXIT STAIRWAY)

THIS DIAGRAM ILLUSTRATES THE SPECIFIC REQUIREMENTS OF THESE REGULATIONS AND IS INTENDED ONLY AS AN AID FOR BUILDING DESIGN AND CONSTRUCTION

VESTIBULE

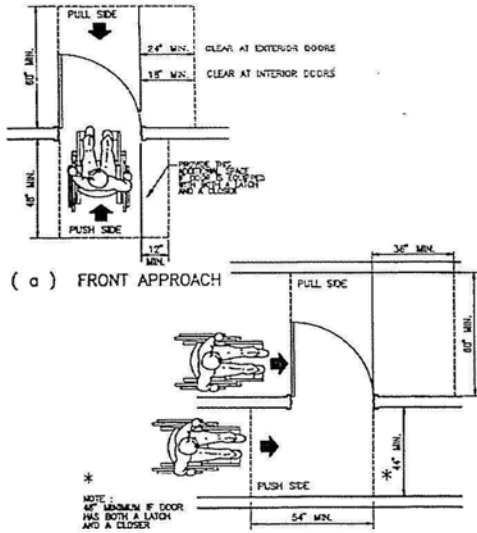

(a) FRONT APPROACH

(b) HINGE APPROACH

THIS DIAGRAM ILLUSTRATES THE SPECIFIC REQUIREMENTS OF THESE REGULATIONS AND IS INTENDED ONLY AS AN AID FOR BUILDING DESIGN AND CONSTRUCTION

LEVEL MANEUVERING CLEARANCE AT DOORS

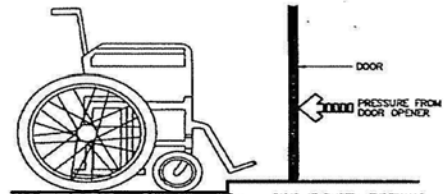

BUMP AT RAISED THRESHOLD BLOCKS SMALL WHEELS
SMOOTH POLISHED FLOOR PREVENTS TRACTION ON MOVING WHEELS

PROBLEM: THE CONDITION SHOWN ABOVE OFTEN MAKES ROOMS INACCESSIBLE TO WHEELCHAIRS

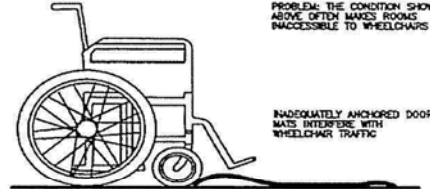

INADEQUATELY ANCHORED DOOR MATS INTERFERE WITH WHEELCHAIR TRAFFIC

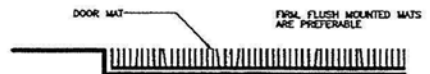

FIRM FLUSH MOUNTED MATS ARE PREFERABLE

THIS DIAGRAM ILLUSTRATES THE SPECIFIC REQUIREMENTS OF THESE REGULATIONS AND IS INTENDED ONLY AS AN AID FOR BUILDING DESIGN AND CONSTRUCTION

OBSTRUCTIONS

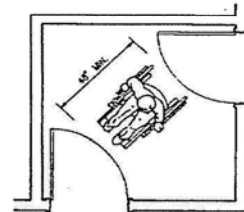

(a) DOORS AT ADJACENT WALLS

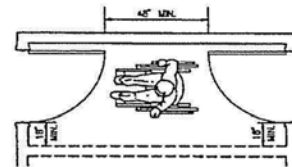

(b) DOORS AT OPPOSITE WALLS

THIS DIAGRAM ILLUSTRATES THE SPECIFIC REQUIREMENTS OF THESE REGULATIONS AND IS INTENDED ONLY AS AN AID FOR BUILDING DESIGN AND CONSTRUCTION

VESTIBULE

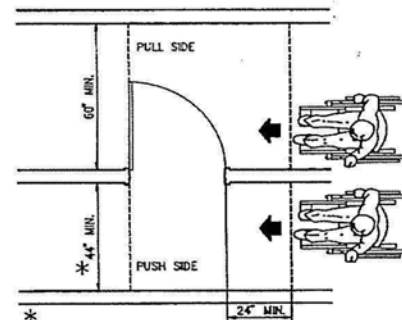

NOTE: 48" MINIMUM IF DOOR HAS A CLOSER

(c)

LATCH APPROACH

THIS DIAGRAM ILLUSTRATES THE SPECIFIC REQUIREMENTS OF THESE REGULATIONS AND IS INTENDED ONLY AS AN AID FOR BUILDING DESIGN AND CONSTRUCTION

LEVEL MANEUVERING CLEARANCE AT DOORS (Continued)

BATHING AND TOILET FACILITIES:

All sanitary facilities that serve buildings, facilities or portion of buildings that are required by handicapped regulations to be accessible to persons with disabilities shall comply. Separate facilities are required where provided for the non disabled. Where unisex facilities are provided for the non disabled, such unisex facilities shall be provided for persons with disabilities. Where facilities are to be used solely by small children, the specific heights may be adjusted to meet their accessibility needs.

TOILET ROOM FIXTURES AND ACCESSORIES:

Water closet height = Min. 17" to max. 19"

Water closet flush control = Max. 44" above floor

Grab bars = 1 1/4" ϕ - 1 1/2" ϕ mounted at 33" above floor with 1 1/2" wall clearance

Towel, sanitary napkins and waste receptacles = Max. 40" above floor

Urinal = Min. 14" from wall and 17" above floor with operable control at max. 44" above floor

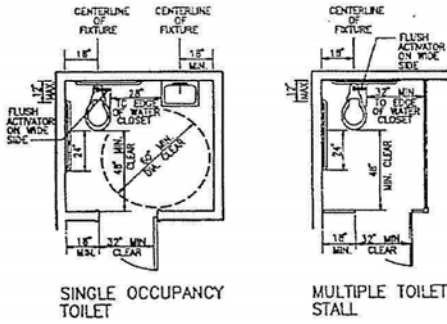

SINGLE OCCUPANCY TOILET

MULTIPLE TOILET STALL

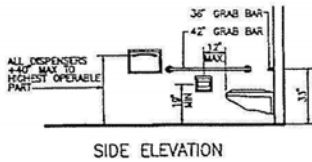

SIDE ELEVATION

THIS DIAGRAM ILLUSTRATES THE SPECIFIC REQUIREMENTS OF THESE REGULATIONS AND IS INTENDED ONLY AS AN AID FOR BUILDING DESIGN AND CONSTRUCTION

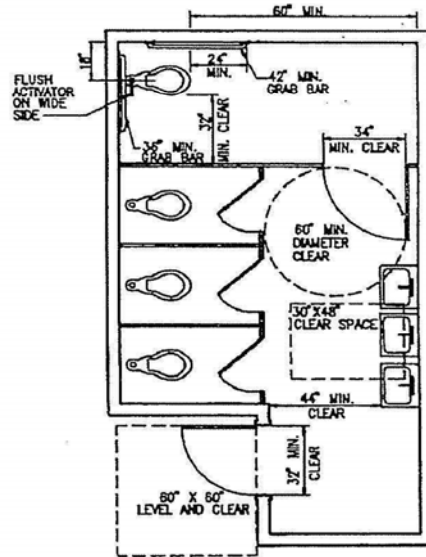

THIS DIAGRAM ILLUSTRATES THE SPECIFIC REQUIREMENTS OF THESE REGULATIONS AND IS INTENDED ONLY AS AN AID FOR BUILDING DESIGN AND CONSTRUCTION

MULTIPLE ACCOMMODATION TOILET

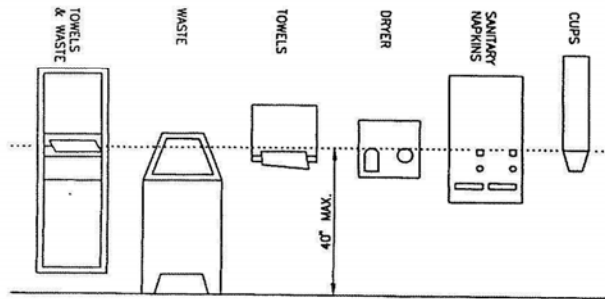

TOILET ACCESSORIES

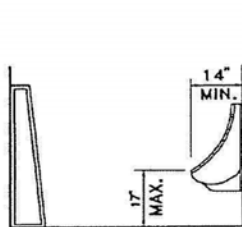

URINALS

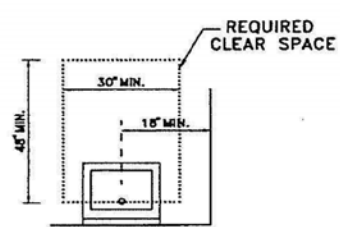
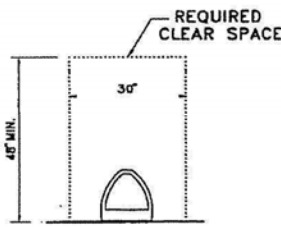

LAVATORIES

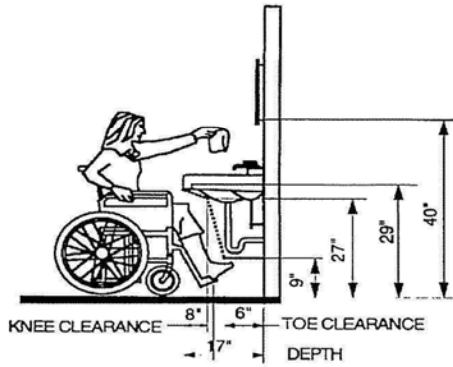

THIS DIAGRAM ILLUSTRATES THE SPECIFIC REQUIREMENTS OF THESE REGULATIONS AND IS INTENDED ONLY AS AN AID FOR BUILDING DESIGN AND CONSTRUCTION

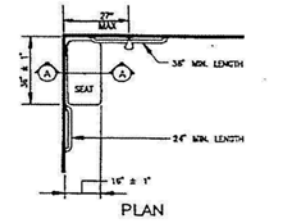

PLAN

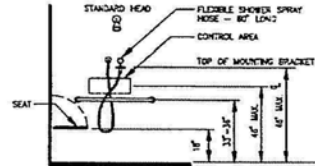

SECTION A-A

THIS DIAGRAM ILLUSTRATES THE SPECIFIC REQUIREMENTS OF THESE REGULATIONS AND IS INTENDED ONLY AS AN AID FOR BUILDING DESIGN AND CONSTRUCTION

OPEN SHOWER

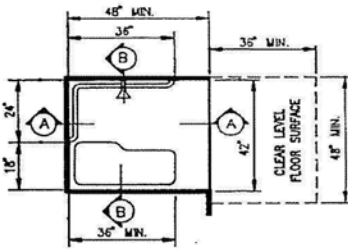

PLAN

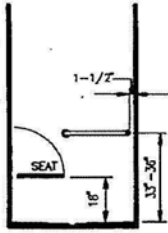

SECTION B-B

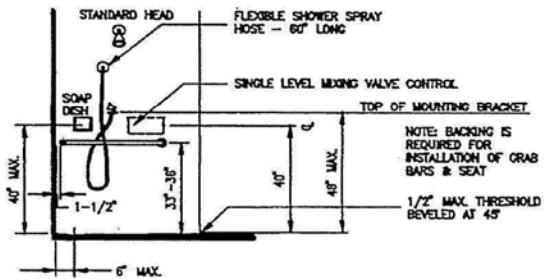

SECTION A-A

THIS DIAGRAM ILLUSTRATES THE SPECIFIC REQUIREMENTS OF THESE REGULATIONS AND IS INTENDED ONLY AS AN AID FOR BUILDING DESIGN AND CONSTRUCTION

ROLL-IN SHOWER STALL

WATER FOUNTAINS (Drinking) AND PUBLIC TELEPHONE:

When water fountains and public telephones are provided, they shall comply with handicapped regulations as illustrated below.

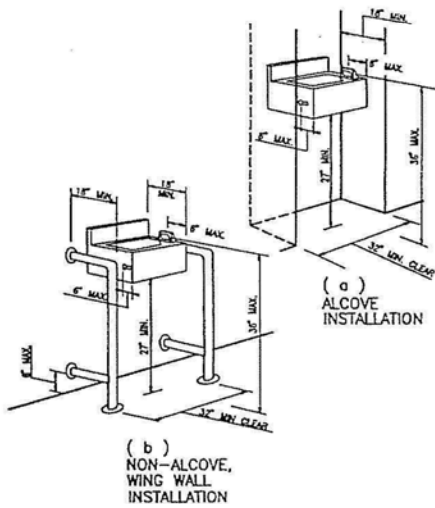

(b) NON-ALCOVE, WING WALL INSTALLATION

THIS DIAGRAM ILLUSTRATES THE SPECIFIC REQUIREMENTS OF THESE REGULATIONS AND IS INTENDED ONLY AS AN AID FOR BUILDING DESIGN AND CONSTRUCTION

WATER FOUNTAINS

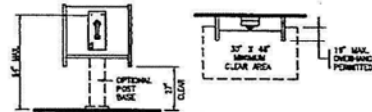

(a) SIDE REACH ARRANGEMENT

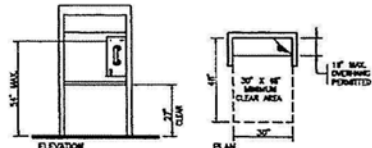

(b) FULL HEIGHT ENCLOSURE

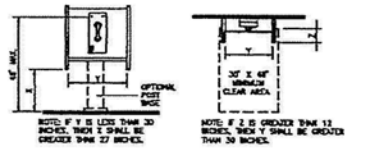

(c) FORWARD REACH ARRANGEMENT

THIS DIAGRAM ILLUSTRATES THE SPECIFIC REQUIREMENTS OF THESE REGULATIONS AND IS INTENDED ONLY AS AN AID FOR BUILDING DESIGN AND CONSTRUCTION

MOUNTING HEIGHTS AND CLEARANCES FOR TELEPHONES

SIGNS & IDENTIFICATIONS

AT PARKING SPACES:

- Required when 5 or more spaces
- Each parking space to have permanent (70 sq. in.) reflectionized porcelain enameled steel sign
- Free standing signs located at interior end of parking space mounted minimum of 80" above finish grade
- Wall mounted signs located at interior end of parking space mounted minimum of 36" above finish grade
- At van accessible space, all "VAN ACCESSIBLE" sign mounted below the symbol of accessibility
- Tow away signs at each entrance to parking area or adjacent to accessible parking spaces. Choose one of the following:

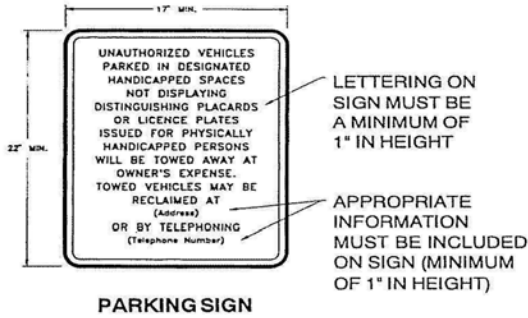

PARKING SIGN

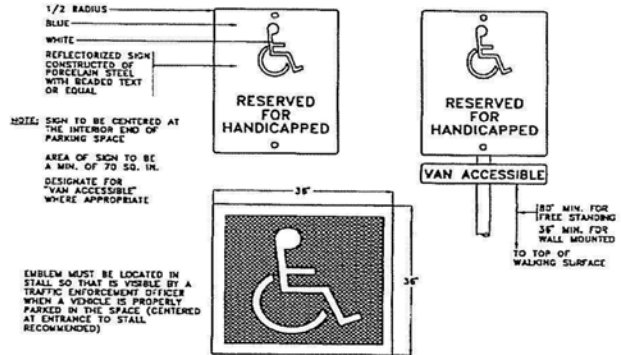

HANDICAPPED PARKING SIGN (TYP)

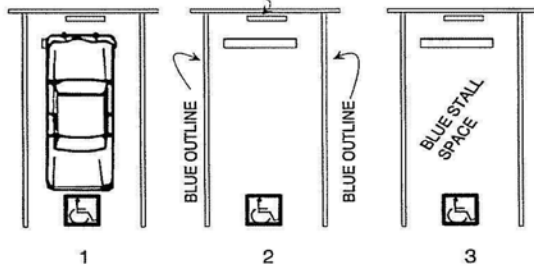

1. Handicapped symbol 36" x 36" in white on blue background shall be visible when vehicle is parked.
2. Stall outlines in blue with handicapped symbol in white located anywhere in the stall place.
3. Stall space in blue with handicapped symbol in white located anywhere in the stall space.

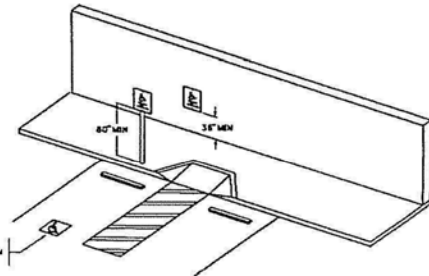

PARKING SPACE SIGNAGE

AT TOILET FACILITIES:

Doorways leading to toilet facilities shall have geometric signs centered on the door at a height of 60" above floor and their color and contrast shall be distinctly different from the color and contrast of the door. An additional sign pictogram shall be installed on the wall adjacent to the latch outside of the door at 60" above floor with raised letters & braille.

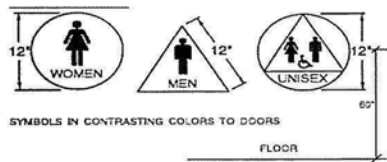

(DOOR SIGNS) GEOMETRIC



WALL SIGNS (PICTOGRAM)

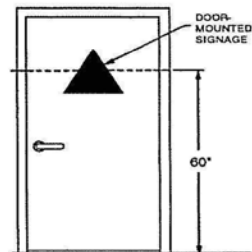

TOILET ROOM SIGNAGE

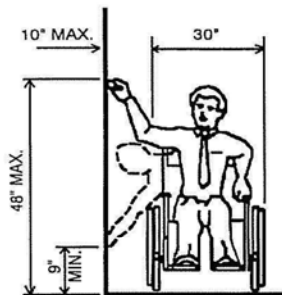
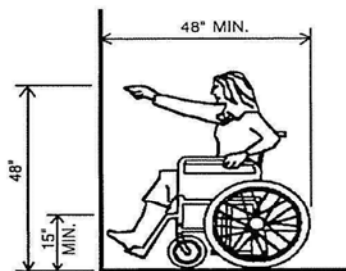

FOR LIGHT SWITCHES, HVAC THERMOSTATS, HOOD, VENTS AND APPLIANCE CONTROLS.

MINIMUM HEIGHT FOR ELECTRICAL RECEPTACLE WALL OUTLETS.

FOREWARD AND SIDE REACH

AT ROOM IDENTIFICATION:

Examples, name of room, room numbers, exits.

Requirements : Raised letters & Braille

- Location: On wall adjacent to latch side of door, 60" above floor. (At double doors, on right wall.)
- Raised letter Characteristics:
 - a. 5/8" to 2" high, raised 1/32"
 - b. sans serif, upper case
 - c. non-glare
 - d. contrast: Light-on-dark or dark-on-light
- Braille: Grade II, dots = 1/10" on center in each cell with 2/10" space between cells, raised 1/40"
- Obstacles: A person must be able to approach within 3" of signage without encountering protruding objects or standing (sitting) within swing of door.
- Pictograms:
 - a. Location: Where used in permanently signed rooms & spaces, equivalent verbal description placed below in raised letters & Grade II Braille.
 - b. Border Dimension: Min. 6" high

EXISTING BUILDINGS

GENERAL CONCEPT:

All existing buildings and facilities, when alterations, structural repairs or additions are made to such buildings or facilities, shall comply with all provisions of New Buildings, Site Accessibility, Accessibility for Entrances, Exits and Paths of Travel, except as modified below. There requirements shall apply only to the area of specific alteration, structural repair or addition and shall include those additional areas and facilities listed below:

- A primary entrance to the building or facility
- The primary path of travel to the specific area of alteration, structural repair or addition
- Sanitary facilities, drinking fountains and public telephones serving the area

EXCEPTIONS:

1. When the total construction cost of alterations, structural repairs or addition does not exceed a valuation threshold of \$113,586.07 as of March, 2006 (updated annually), and the building official finds that compliance with the handicapped regulations creates an "unreasonable hardship", compliance shall be limited to the actual work of the project. For the purpose of this exception, an "unreasonable hardship" exists when cost of an accessible entrance, path of travel, sanitary facilities, public phones and drinking fountains is proportionate to the cost of the project. That is:

FIVE FEATURES	\$,	accessible entrance
	+	\$, accessible path of travel from arrival points
	+	\$, accessible sanitary facilities (1 per sex)
	+	\$, accessible drinking fountain
	+	\$, accessible public phone
<hr style="border: 0.5px solid black;"/>		
	=	\$ total > 20% x cost of the project
	=	("unreasonable hardship")

Once an "unreasonable hardship" has been established and granted by the Building Official, up to 20% of total construction cost not including the five features noted above must be spent on making accessible elements comply in the following order of priority:

- An accessible entrance
- An accessible route to the altered area
- At least one accessible restroom for each sex
- Accessible telephones
- Accessible drinking fountains, and
- When possible, additional accessible elements such as storage and alarms

* Application for unreasonable hardship exception is included in this bulletin

2. Regardless of how much money is being spent on remodeling, the following buildings must allot up to 20% of the project cost (computed without the cost of making the FIVE FEATURES accessible) on making the FIVE FEATURES accessible:

- a. Office buildings & passenger vehicle stations three or more stories & 3000 or more sq. ft. per floor
- b. Offices of physicians & surgeons

- c. Shopping centers (defined as one or more retail stores)
- d. Other buildings three or more stories & > 3000 sq. ft. per floor, if a reasonable portion of services sought by the public is available on the accessible level.

3. Alterations to entrances, toilet facilities, elevators, steps & handrails to meet the accessibility requirements may be limited to the actual work of the project. Alterations to meet the "readily achievable" requirements of Title III of the Americans with Disabilities Act may be limited to the actual work of the project.
4. Projects which consist only of heating, ventilation, air conditioning, reroofing, electrical work not involving placement of switches & receptacles, cosmetic work that does not affect items regulated by this code, such as painting, are not accessibility requirements.
5. When an unreasonable hardship exists, then the building official may grant unreasonable hardship if equivalent facilitation is provided.
6. These regulations shall not apply when legal or physical constraints would not allow compliance with these regulations or equivalent facilitation without creating an unreasonable hardship as determined by an appeals process.

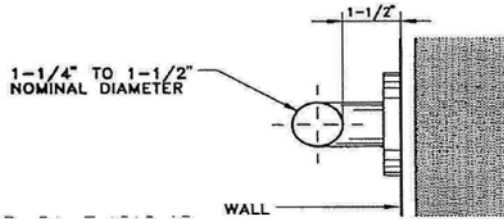

SECTION THROUGH TYPICAL GRAB BAR

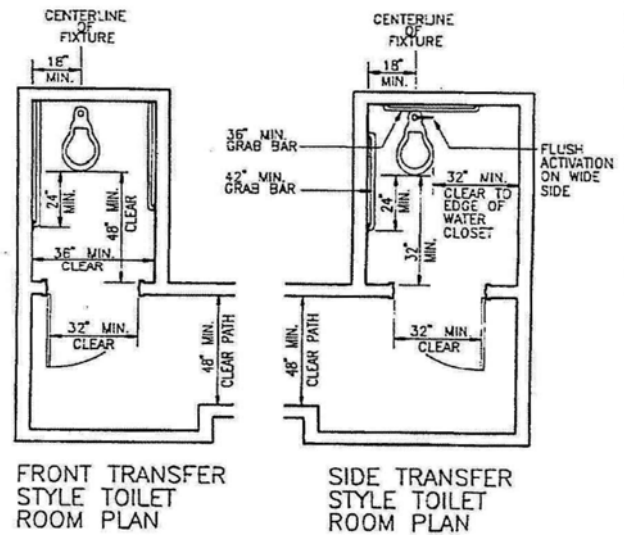

THIS DIAGRAM ILLUSTRATES THE SPECIFIC REQUIREMENTS OF THESE REGULATIONS AND IS INTENDED ONLY AS AN AID FOR BUILDING DESIGN AND CONSTRUCTION

EQUIVALENT FACILITATION FOR EXISTING BUILDINGS ONLY

The State Architect has just published the latest Valuation Threshold used in CBC Sec. 1134B. The table below has been copied from the State Architect's web site at:

http://www.dsa.dgs.ca.gov/UniversalDesign/ud_threshold.htm

Valuation Threshold for Alterations, Structural Repairs or Additions to Existing Buildings

Per 2001 California Building Code Section 1134B.2.1 Exception 1, the 2007 valuation threshold is \$116,837.68 and will be updated again in January, 2008.

The annual valuation threshold is based on the January 1981 threshold of \$50,000.00 as adjusted using the ENR 20 Cities Construction Cost Index, as published by Engineering News-Record, McGraw-Hill Publishing Company, for January of each year.

Valuation threshold for recent years:

Year	ENR Construction Cost Index (Jan.):	Valuation Threshold
2007	7879.58	\$ 116,837.68
2006	7660.29	\$ 113,586.07
2005	7297.24	\$ 108,202.79
2004	6824.90	\$ 101,198.98
2003	6580.54	\$ 97,575.63
2002	6461.81	\$ 95,815.11
2001	6280.85	\$ 93,131.86
2000	6130.36	\$ 90,900.40